

STAIRLIFT INSTALLATION GUIDE

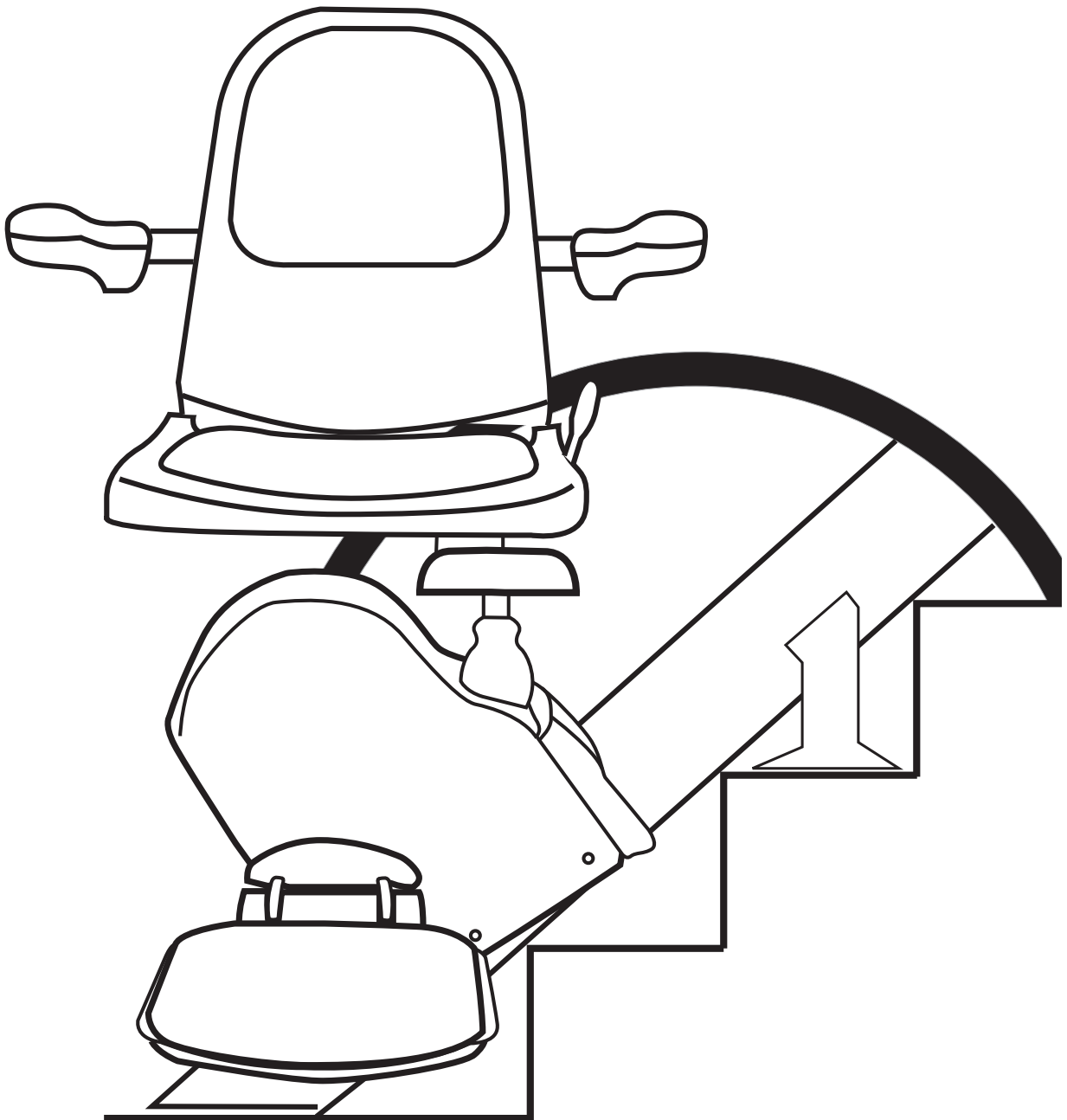

CONTENTS

Health And Safety Hazards	3		
Unpacking the Stairlift Carriage	4		
Pre-Installation Procedure	5		
Box Contents	6		
Installation Tools	9		
1.1	Required	9	
	Optional	10	
Installation	11		
1.2	Installation Procedure	11	
	1.2.1	Preparation on Site	11
	1.2.2	Joining the Rail	12
	1.2.3	Installing the Rail	13
	1.2.4	Installing the Stairlift Carriage	15
	1.2.5	Setting Seat Angle	17
	1.2.6	Setting Footrest Angle	20
	1.2.7	Installing the Seat	21
	1.2.8	Setting Top Stopping Point	24
	1.2.9	Fixing Down the Rail	25
	1.2.10	Connecting the Transformer	25
1.3	Safety Checks	27	
	1.3.1	Check Controls	27
	1.3.2	Check Remote Controls	27
	1.3.3	Check Safety Sensors	28
	1.3.4	Check Stopping Limits	29
	1.3.5	Check Seat Swivel	29
	1.3.6	Check Battery Isolation Switch	30
	1.3.7	Check Key Switch	30
	1.3.8	Hand Winding	30
	1.3.9	Labelling	30
	1.3.10	Check Correct Fixing of Carriage to Rail	30
1.4	Demonstrate Stairlift to User	31	
1.5	Maintenance	31	
1.6	Avoiding Unsafe Installations	31	

IMPORTANT!

READ THESE PROCEDURES THOROUGHLY PRIOR TO STAIRLIFT INSTALLATION

Health and Safety Hazards

The following health and safety hazards should be considered when installing the stairlift:

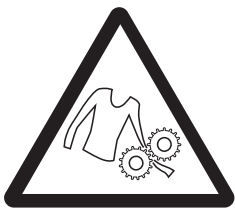

**The risk of loose clothing
or body parts getting
trapped**



**Injury resulting from
drilling, inappropriate use
of tools etc**



**Direct or indirect electrical
contact**



Falling down the stairs



Falling tools



**Correct manual handling
procedure.**

**Use of necessary protection
(safety glasses etc)**



Never use worn tools



**Tripping hazards on the
stairway**

**Follow the current
regulations regarding safe
working practices**

Unpacking the Stairlift Carriage

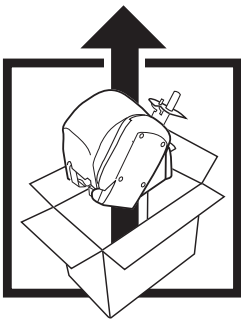

WARNING! Take care when handling the carriage assembly, as this is a heavy component.

Before unpacking carriage it is recommended if possible to unpack box at top of stairway using **PACKING/UNPACKING INSTRUCTIONS** provided.

PLEASE READ PACKAGE INSTRUCTIONS BEFORE REMOVING THE CARRIAGE FROM BOX

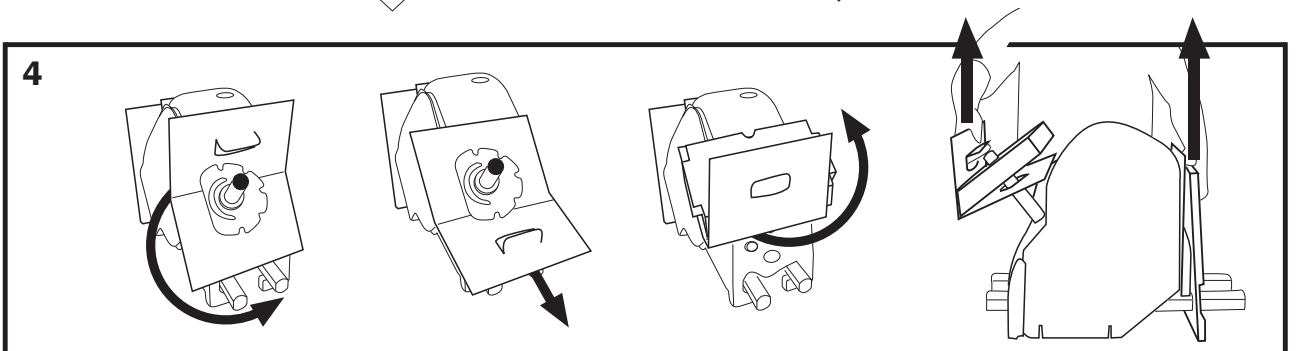
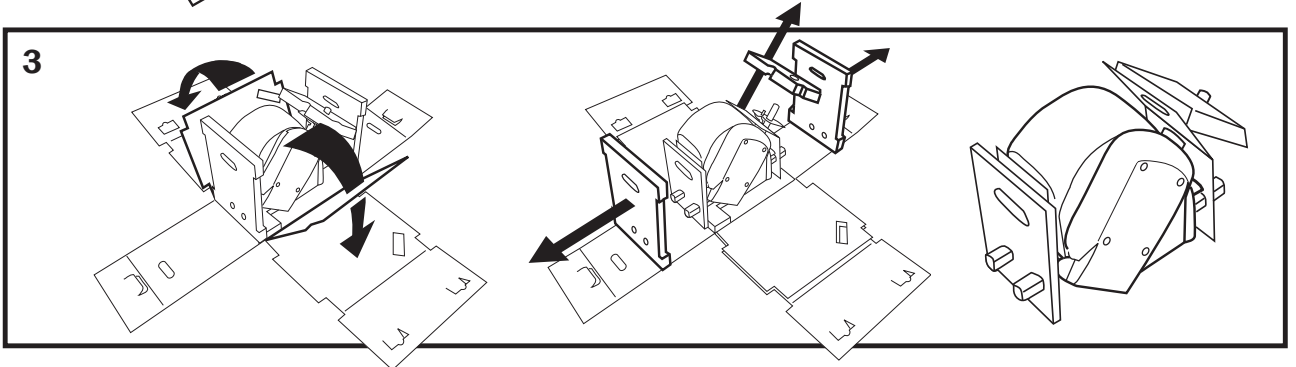
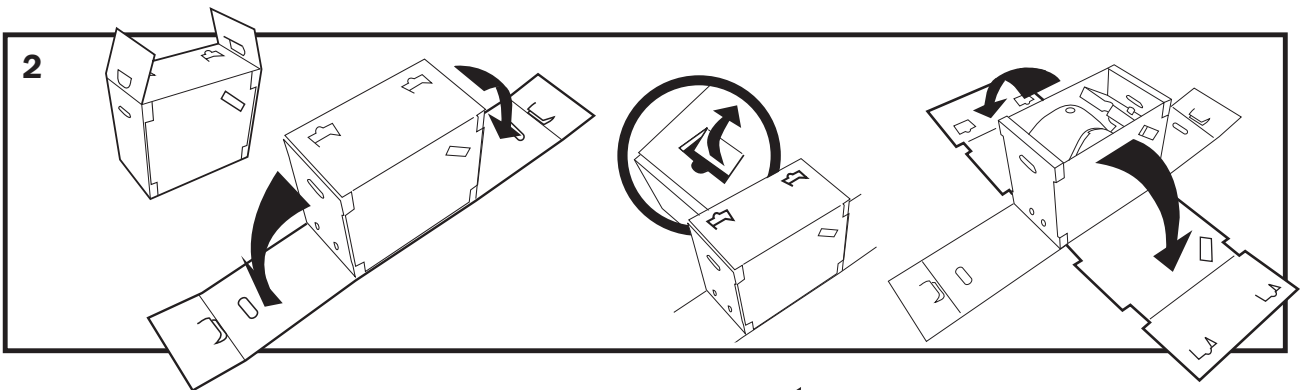
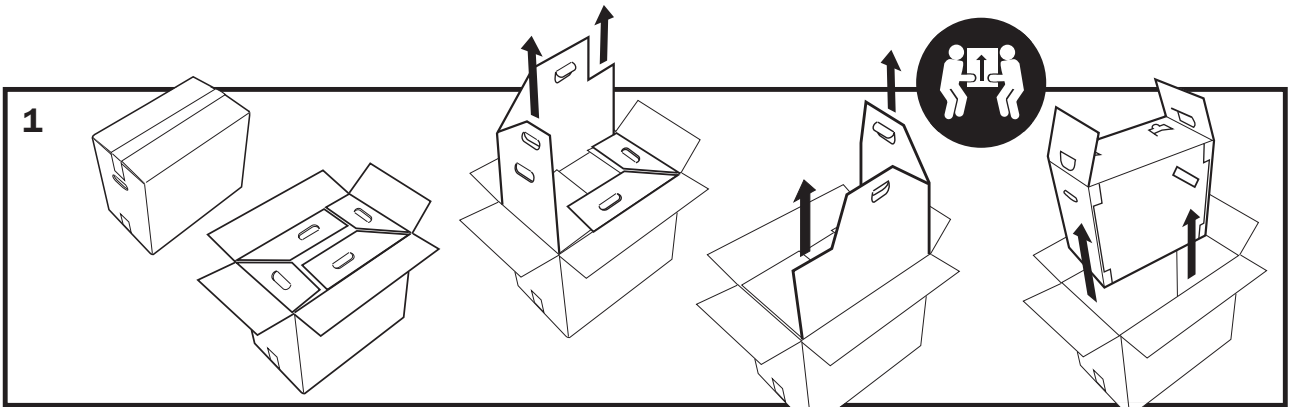

Pre-Installation Procedure

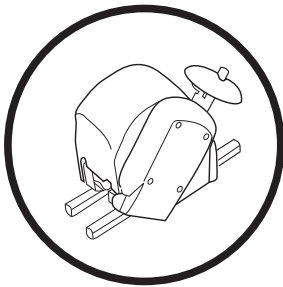

When all the packaging has been removed, leaving the carriage on the shipping rails, carry out the following checks.

 **Ensure that you have the Installation Manual to hand.**

1. Visually inspect the covers and footplate (ie: scratches, cracks, scuffs). Make a note of any issues.

2. Open the box that contains the remotes, batteries and keys.

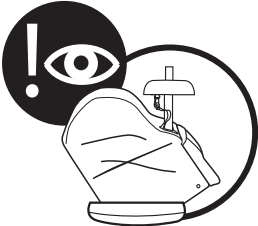
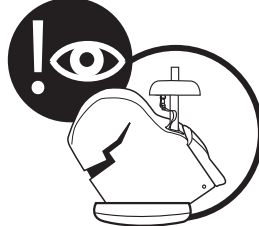



3. Install a battery into a remote.

4. Insert the key into the key switch.

5. Plug the red lead in / switch on the isolation switch.

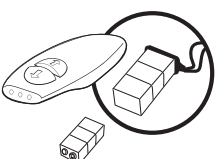
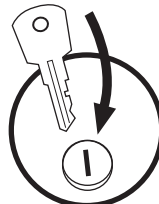
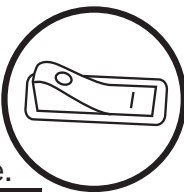
The lift should continually BEEP indicating lift powered up but not receiving a charge. Diagnostic display will show 







6. Turn the key clockwise.

7. Press the red button on the remote control.

8. The lift will **CLICK** (brake release) then emit a low hum (indicating the lift is running).

The diagnostic display will show 

The display will show 

9. Repeat the process by pressing the green button down.

The display will show 





IN THE EVENT OF FAILURE OF ANY OF THESE PRE-INSTALLATION CHECKS, PLEASE CONTACT YOUR AUTHORIZED DEALER

Box Contents

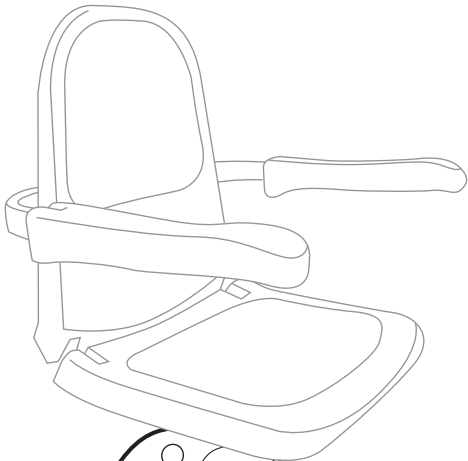
CARRIAGE BOX

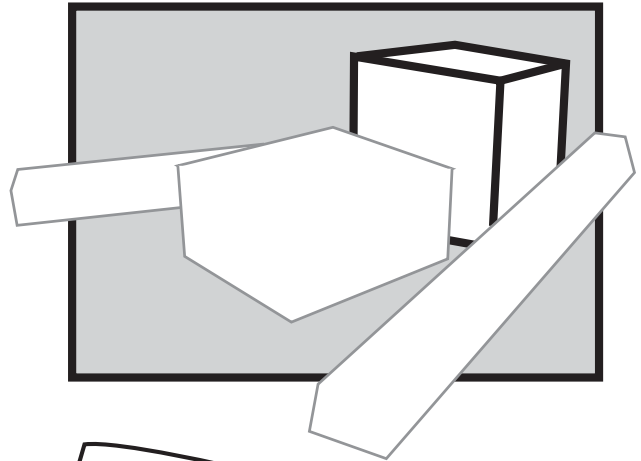

x1 Carriage



x1 Packaging instructions

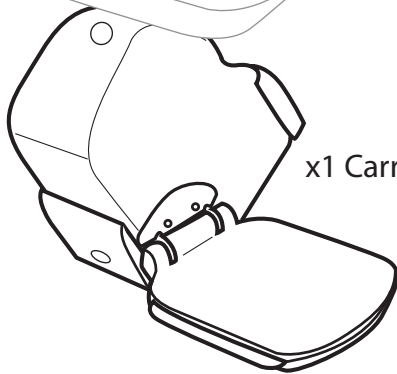

x1 Seat index plate cover

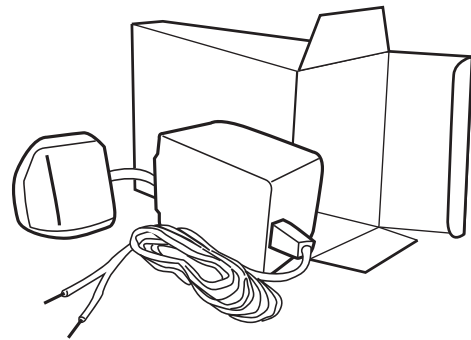
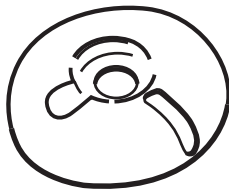

x1 Transformer in box

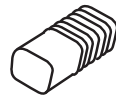
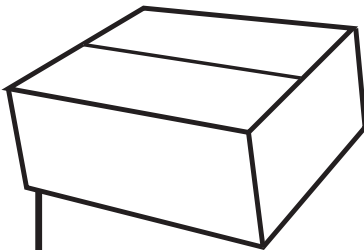

x2 Plastic rail end pieces

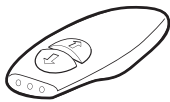

x2 Remote controls

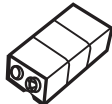

x2 9v Batteries



x2 Keys



x1 Warning sticker



x4 Blanking plugs



x1 User Manual



x1 Warranty card



x1 Installation Instructions

SEAT BOX

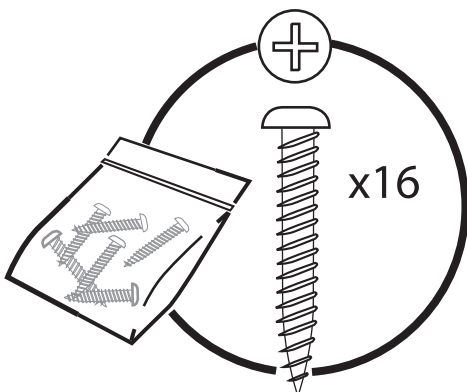
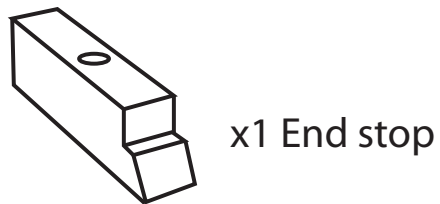
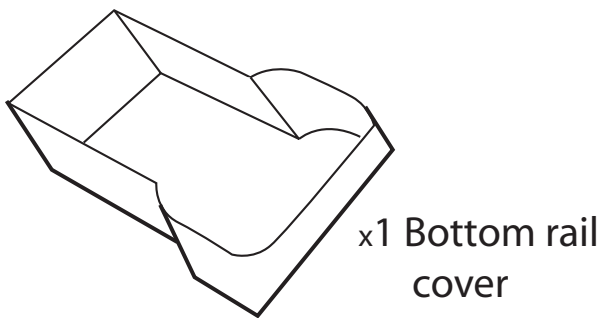
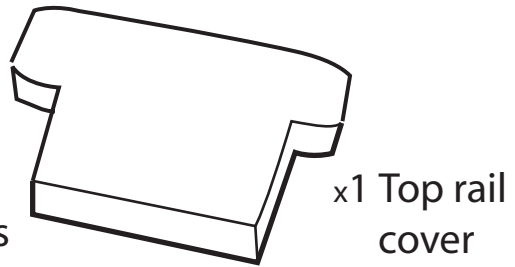
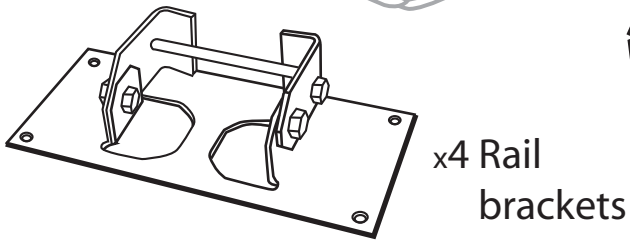
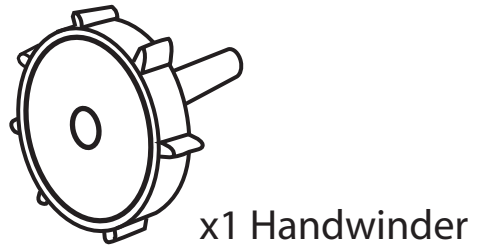
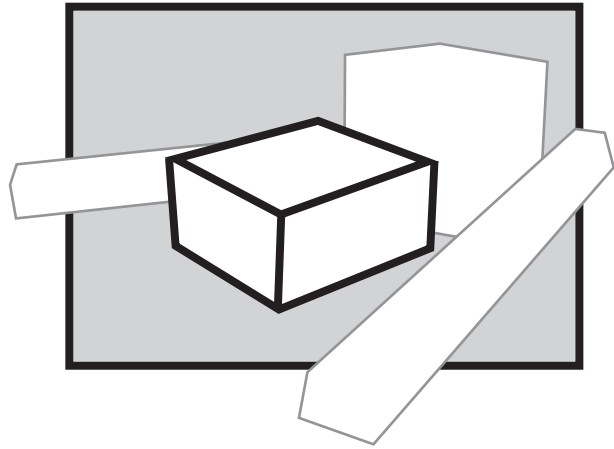
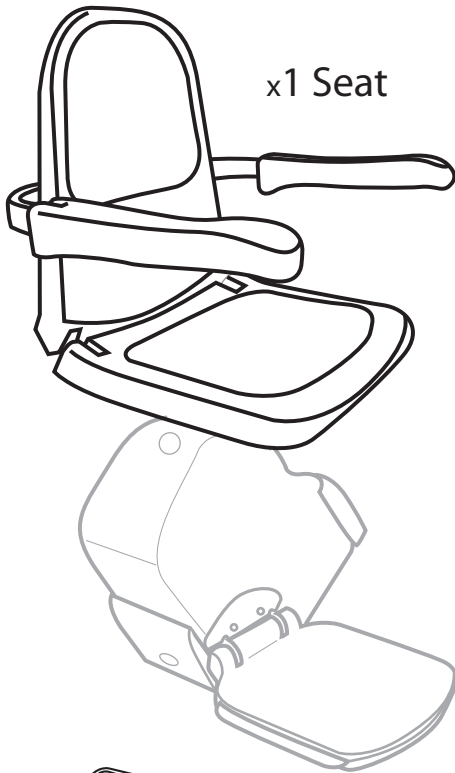

RAIL BOX

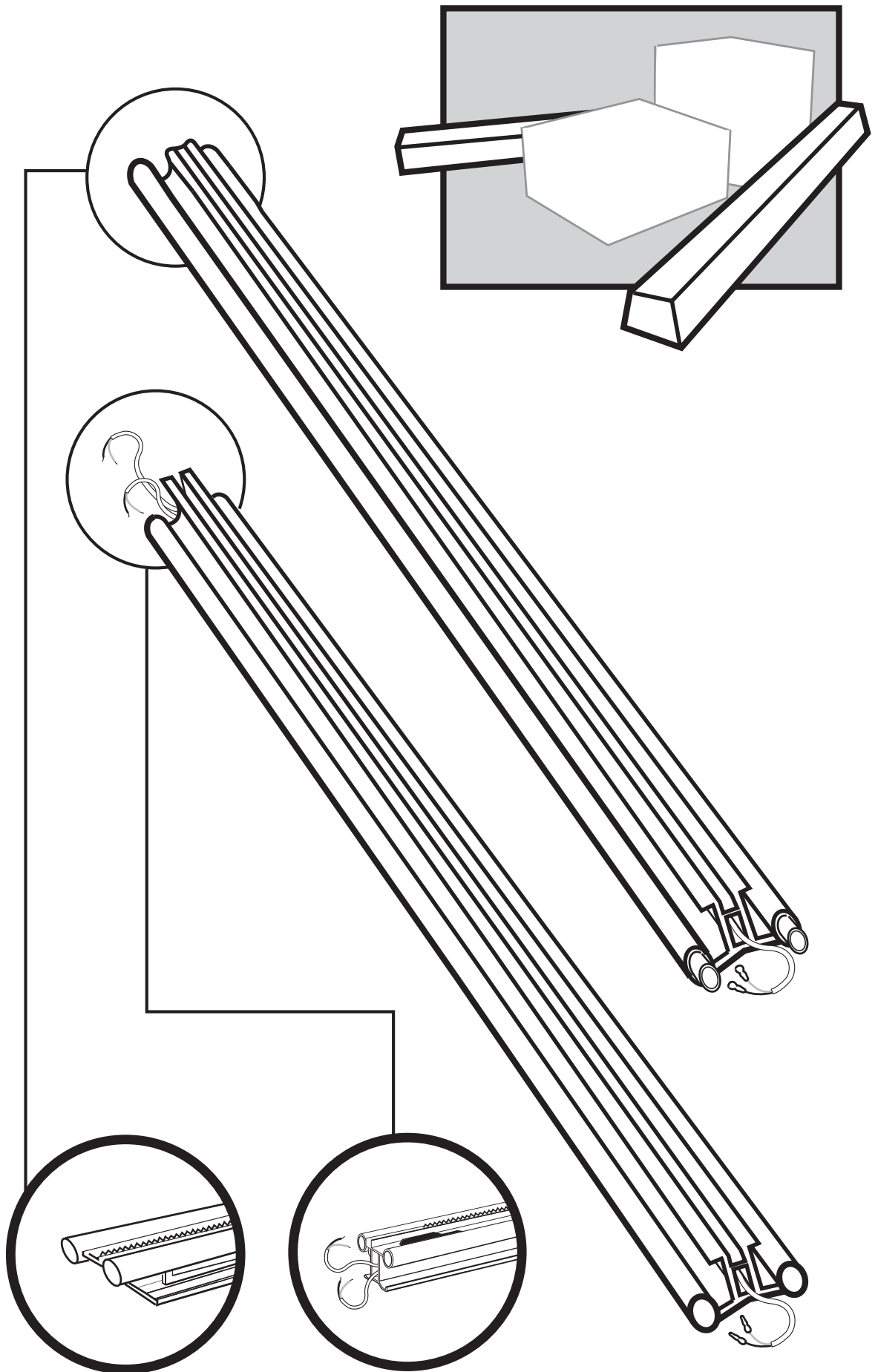

Installation Tools

Required

**Open / ring
Spanner**

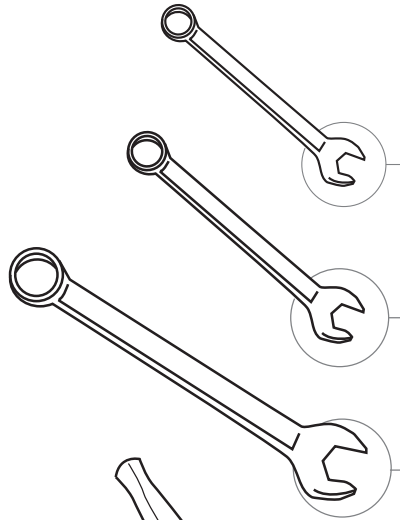

10mm

13mm

17mm

Socket

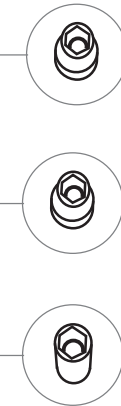

**Socket
ratchet**

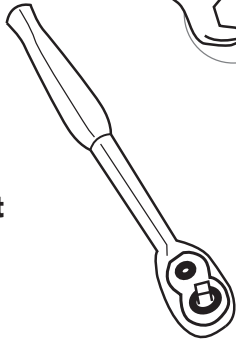

**Socket
extension**



**Flat electrical
terminal
screwdriver**

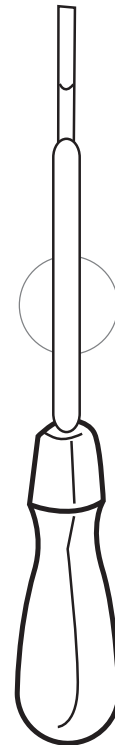

**N°2 / N°3
Phillips
screwdriver**

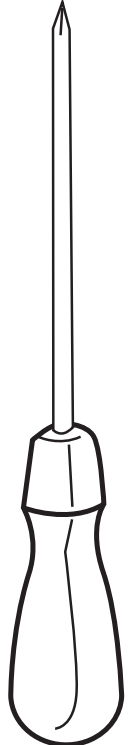

**Spirit
Level**

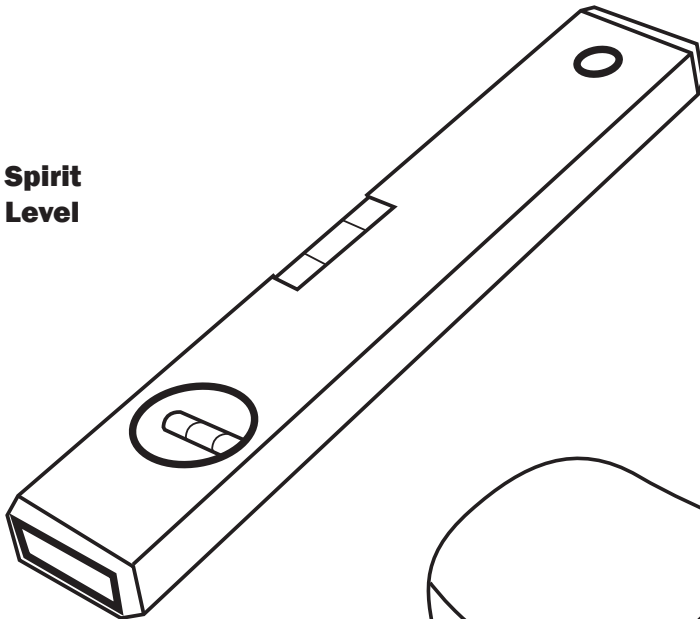

Knife

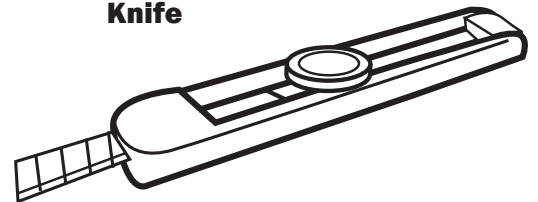

**Tape
Measure**

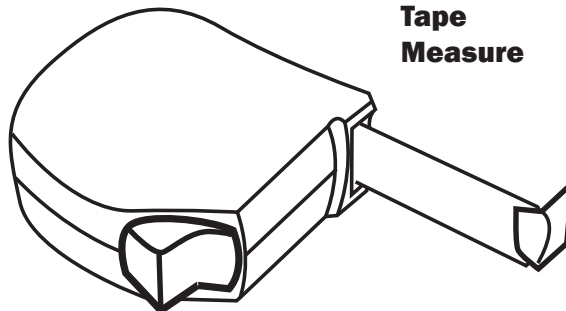

Optional

**Wire
strippers**

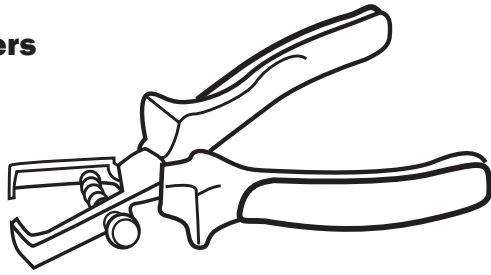

**Side
cutters**

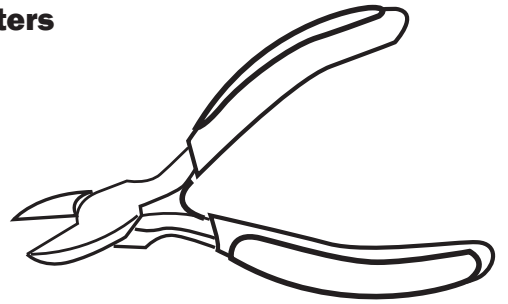

Hammer Drill

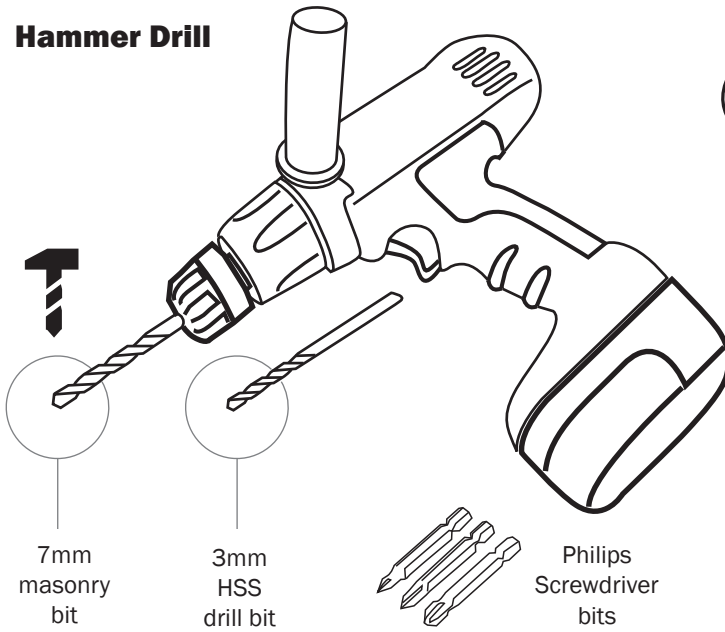

7mm
masonry
bit

3mm
HSS
drill bit

Philips
Screwdriver
bits

Torch

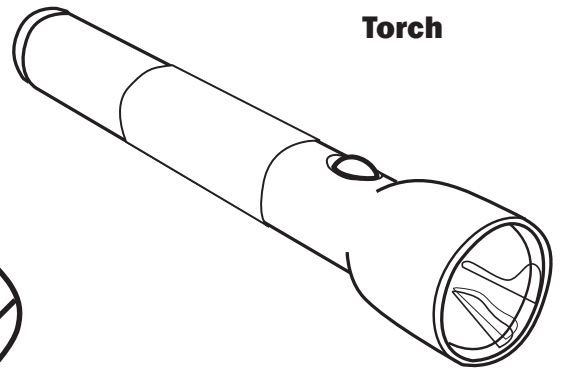

1.2 INSTALLATION PROCEDURE

1.2.1 Preparation on Site

It is recommended that the following examinations be carried out prior to taking the rail into the end users' property:

1.

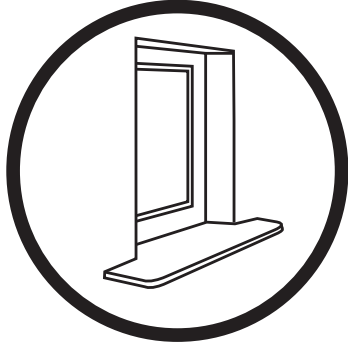

Visually check the site making sure that all obstructions such as window sills, pipes, bulkheads, newel posts etc have been allowed for.

2.



Examine the stairs, remove any removable objects that may get damaged or could cause a tripping hazard when the rail is brought into the property.



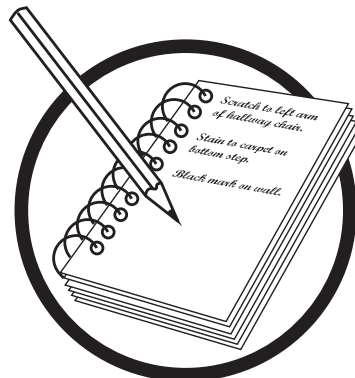

If the stairway is open plan or there is access to the rear of the installation (not against a wall), then the installation must not go ahead until the access has been panelled off.

3.



Identify existing damage to:

-  Decorations
-  Floor coverings, furniture and other furnishings
-  Windows, doors, etc

4.

Do not remove the handrail until the rail has been installed, in case of mis-measure / abort.

1.2.2 Joining the Rail

The stairlift rail is shipped in two pieces that are spliced together during installation.

The upper and lower charge points and upper and lower stopping limit ramps are installed on the rail sections at the factory.



Before positioning, it is recommended, whenever possible, to join the rail together at the base of the stairway making assembly easy.

1. On the bottom rail, loosen the 3 pinch bolts and slide out the 1 inch square joint-bar until it protrudes approximately 4 ½ inches. Tighten the 3 pinch bolts.

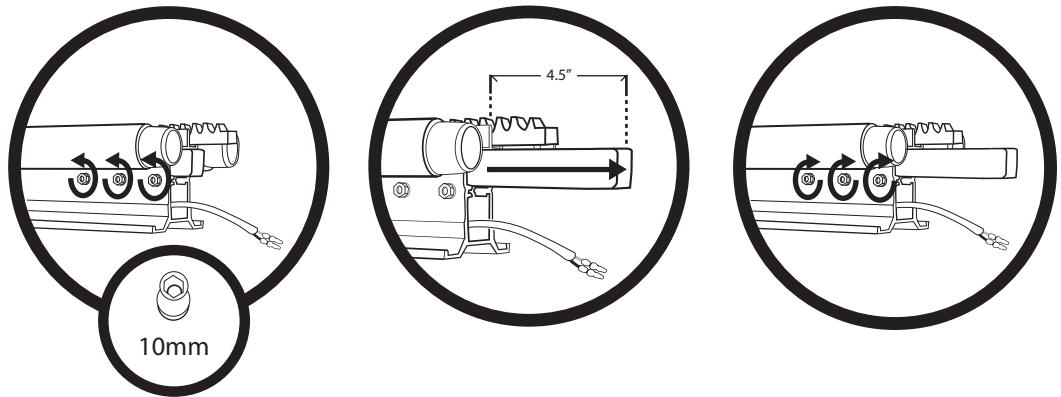

2. On the upper section of the rail, temporarily remove the screw from where the gear rack will go when fully assembled.

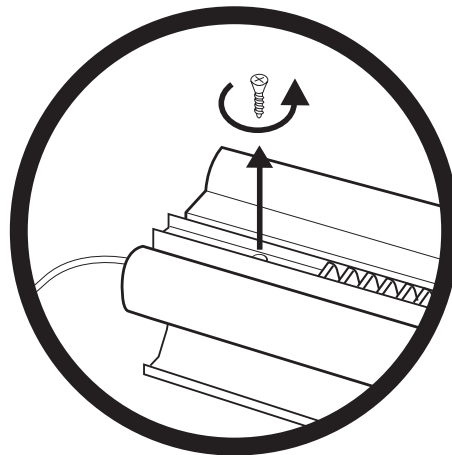

3. Connected to the lower charge point and running through the inside of the lower rail section is a two wire cable that terminates with two female wire connectors.

Connect the male and female wire connectors of the rail cable together (brown to brown, blue to blue).

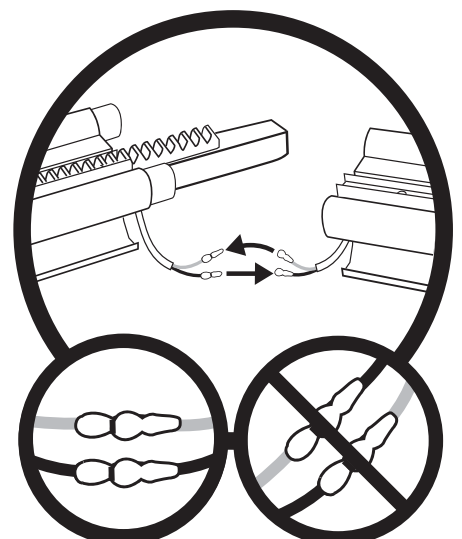

4.

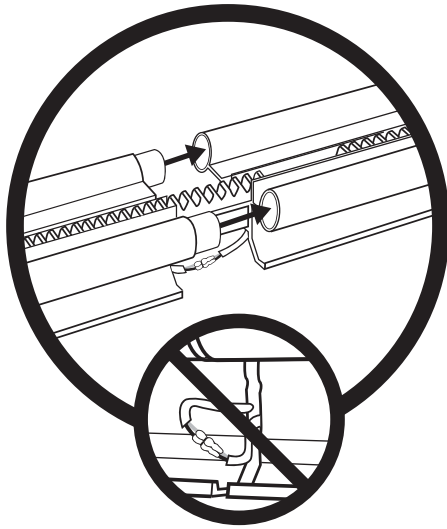

The two rail sections now need to be fixed together.



IMPORTANT!
 Make sure that the wiring isn't trapped between the edges of the rail preventing a flush join.

5.

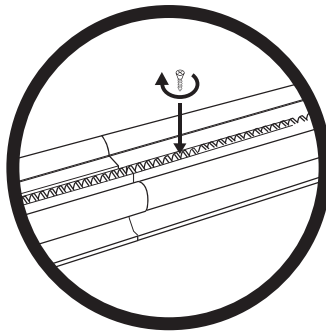
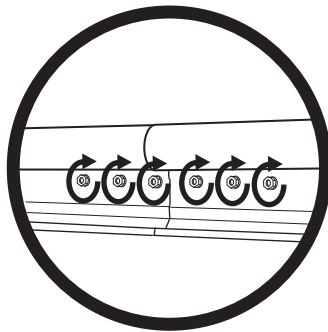

Re-tighten the pinch bolts to hold the joint-bar securely in place, using 2 x 10mm spanners.

Replace the screw into the gear rack and back into the upper rail.



Do not remove the handrail until the rail has been installed, in case of mis-measure / abort.

1.2.3

Installing the Rail

1. Position the rail as one complete assembly on the staircase, with the lower (angled) end resting on the floor, at the bottom of the stairs and the steel toothed rack uppermost. Place the rail end on the bottom of the rail.



2.

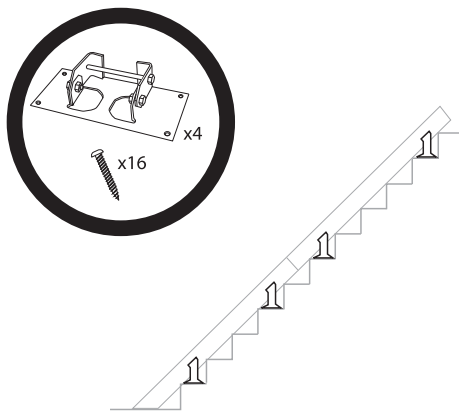

Position the stair brackets underneath the rail - one on the first step, one on the very top step and the middle two either side of the join in the rail.

3.

The stair brackets clamp to the underside of the rail and are secured by tightening the long 13mm nut / bolt, which runs right through each bracket.

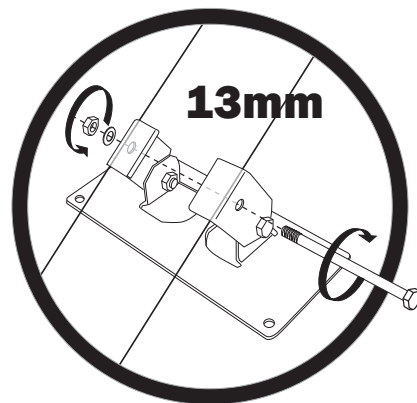
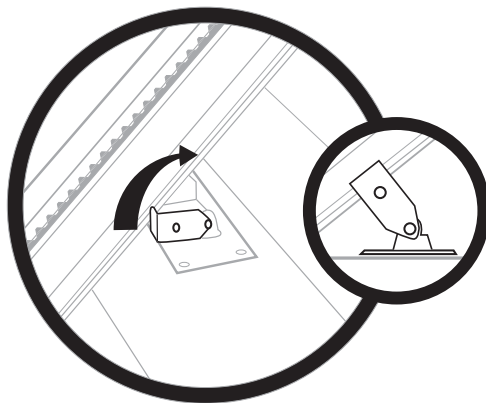

4.

Position the bracket so that it sits firmly on the stair tread and tighten the two short 13mm nut / bolts on either side of the bracket. Do not fix the bracket to the stair tread at this time.

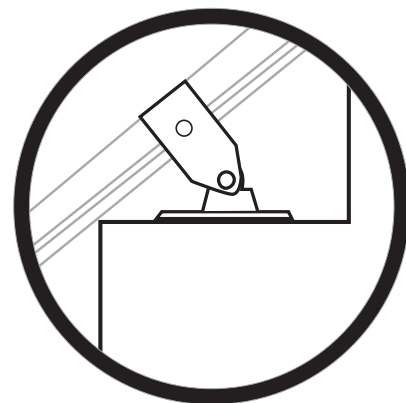
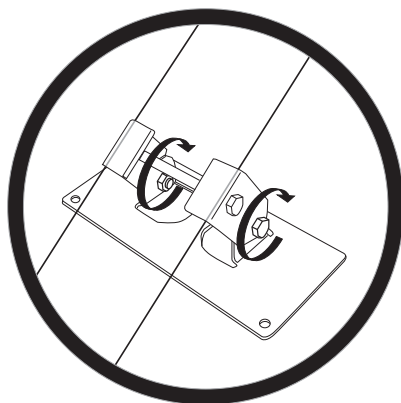

5.

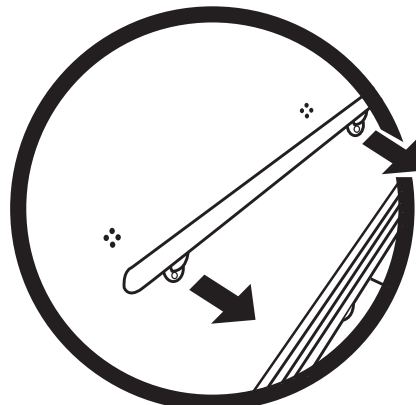

With the rail correctly sitting on the stairs the handrail if fitted can now be removed.

1.2.4 Installing the Stairlift Carriage

1.

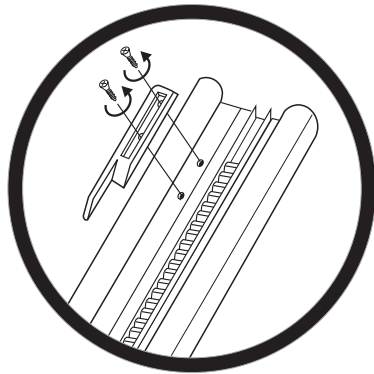

Remove the adjustable upper stopping limit ramp moulding from the top end of the rail.

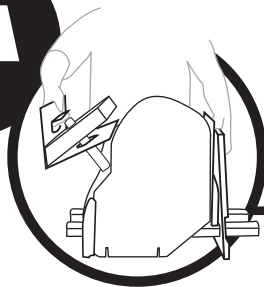

WARNING! Take care when handling the carriage assembly, as this is a heavy component.

2.

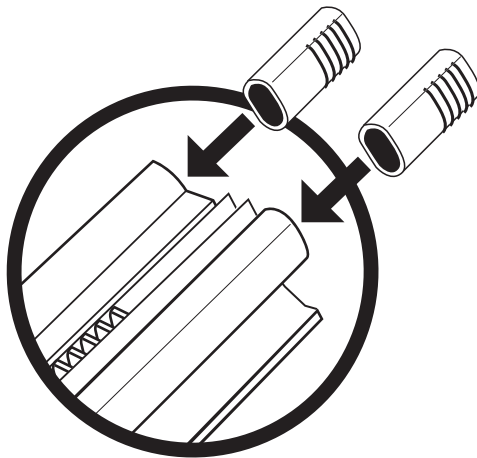

Insert the plastic end pieces to the rail top for Carriage installation.

3.

Place the carriage on the top of the rail, positioning the two rail lengths on the carriage onto the plastic end pieces.

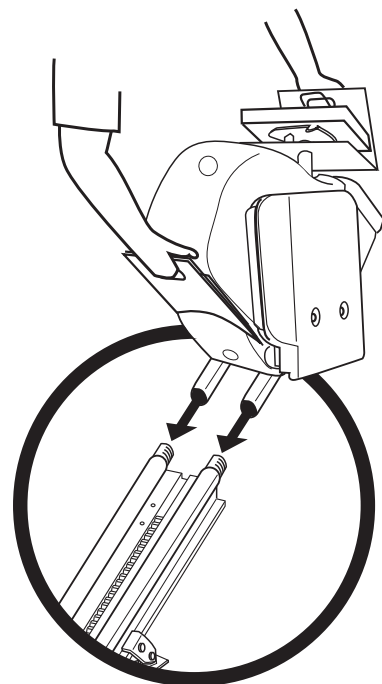

WARNING! Take great care not to damage any of the three micro-switches that protrude from the underneath of the carriage body

4. Switch on the Battery isolation switch and turn the key to the ON position.

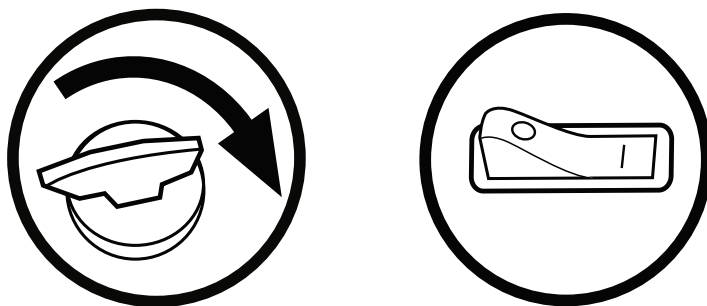

5. Drive the Carriage onto the Rail using a remote control.

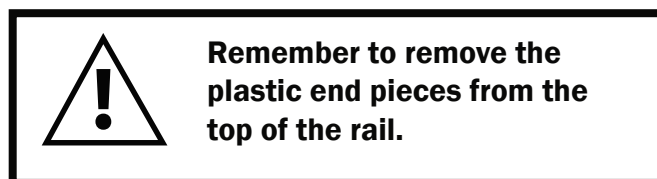
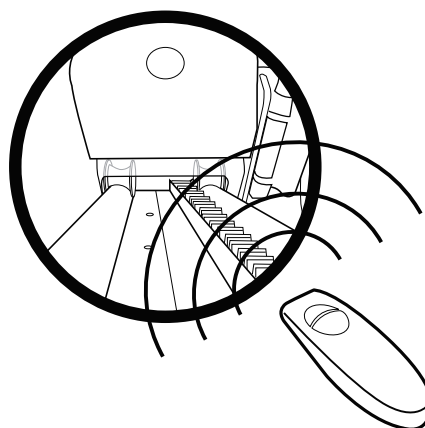

6. Remove the yellow warning labels and transit screws attached to both the upper and lower carriage safety edges, then fit the blanking plugs supplied into the holes.

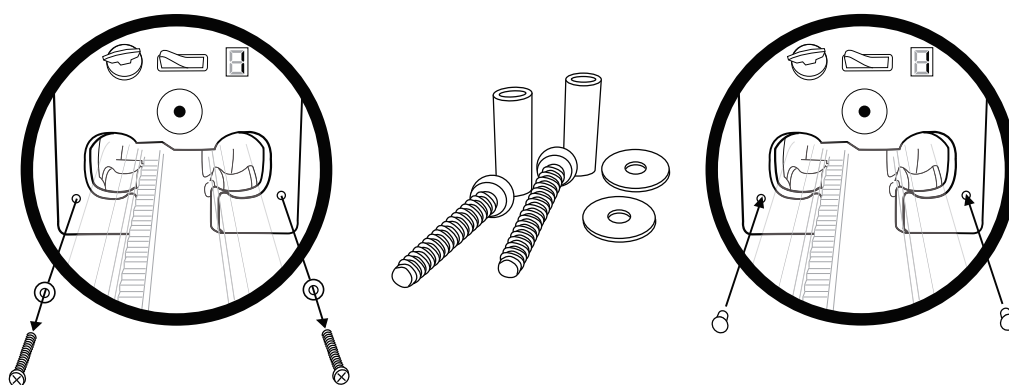

7. Remove the Safe Handling Aid. **SEE PACKING INSTRUCTIONS.**

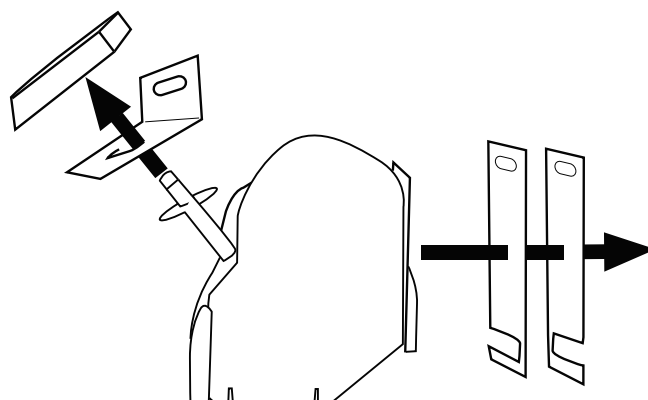

1.2.5

Setting Seat Angle



The following procedure must be **STRICTLY** adhered to, to avoid damage to the chassis plates.

1.

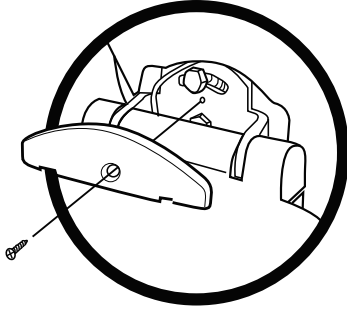

Remove the footrest hinge cover by removing the screw.

2.

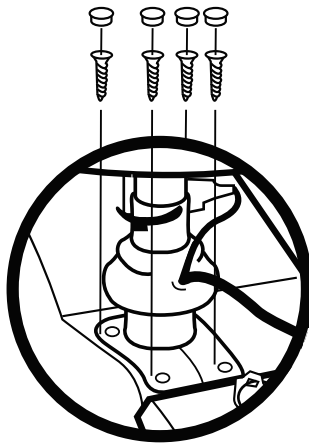

Remove gaitor first.

Remove screw covers.

Undo screws on bezel and remove.

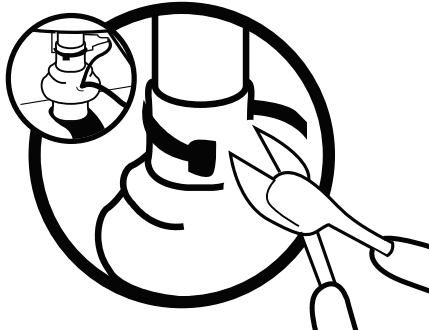
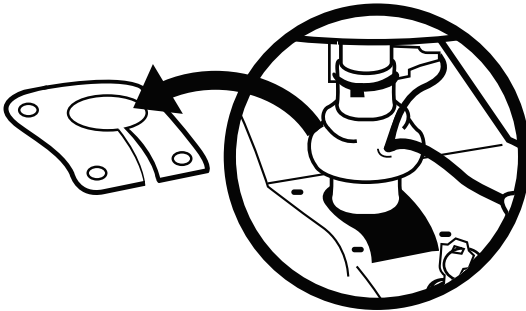

Undo the cable tie and remove the gaitor.

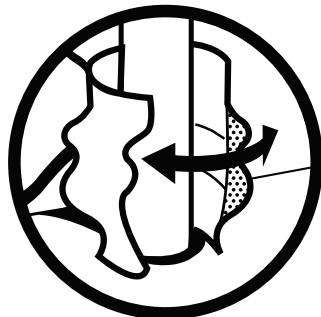

3.

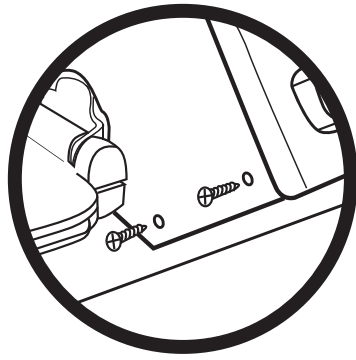

To remove the main carriage cover, remove the 2 screws that are located along the front bottom edge.

4.

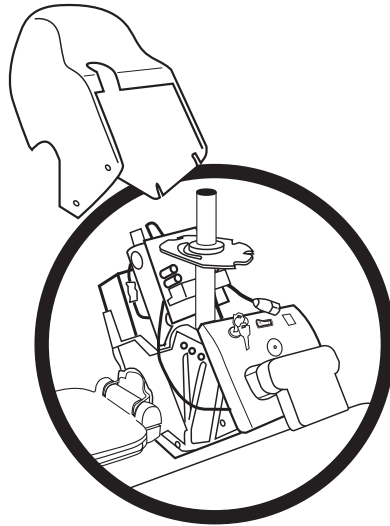

Gradually remove the cover on an angle.

It may be necessary to loosen the footplate adjusting bolt.

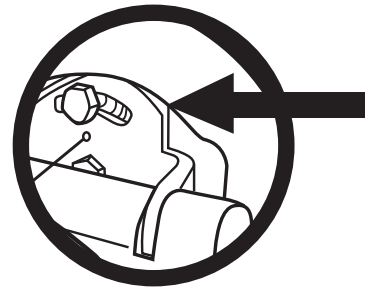

5.

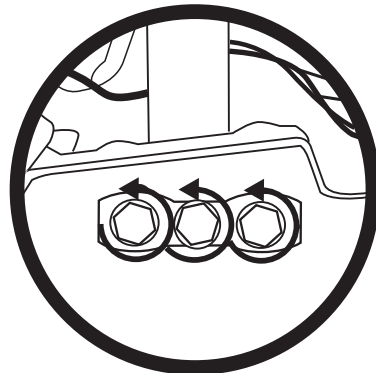

Loosen the 6 horizontal bolts (3 either side) until the post can just move.

6.

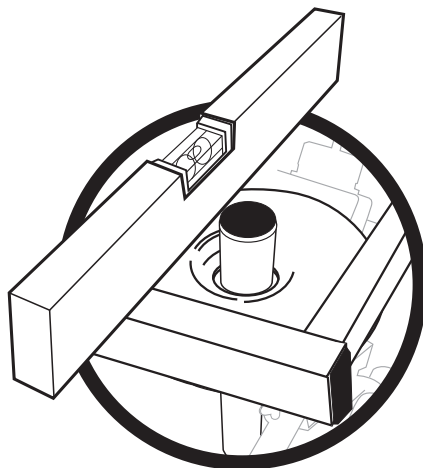

Adjust the seat to the correct angle by placing a spirit level on the seat post platform.

7.

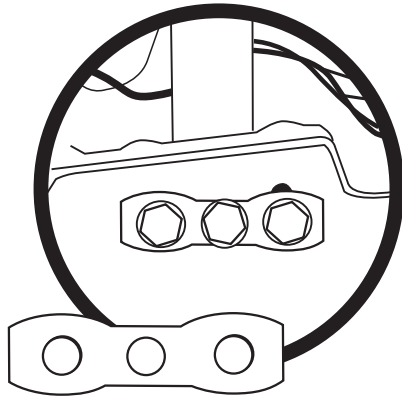

Ensure that the anti-slip clamps (butterfly brackets) are in the correct horizontal position. The serrated side should be facing inward towards the carriage, with the smooth side facing outward.

Also make sure that the bolt washers are located between the bolt head and the anti-slip clamp.

8.

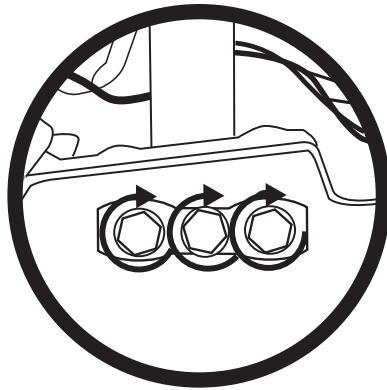

Tighten the 6 horizontal bolts using a 13mm socket torque wrench set to 36Nm (26lb).

9.

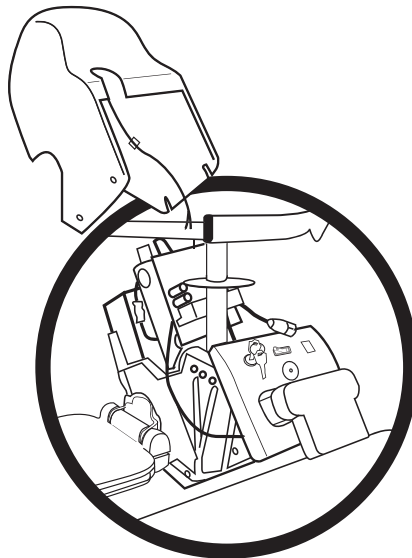

Replace the carriage cover and replace the two screws.

10. Refit the gaitor, (see Page 17, Step 2).

Fit and screw down the bezel. Attach a fresh cable tie around the neck of the gaitor.

1.2.6 Setting Footrest Angle

1.

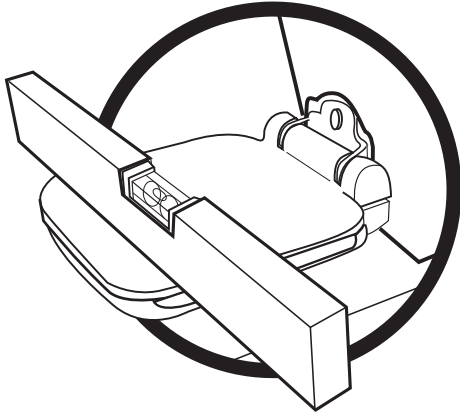

Loosen the centre bolt and adjust to the correct level using the spirit level.

Once level, tighten the bolt back up.

2.

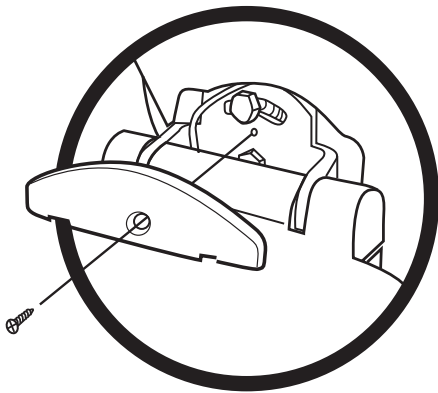

Return the footrest hinge cover by replacing the screw.

1.2.7 Installing the Seat

The seat assembly now needs to be fitted to the seat post on the carriage.
Carry this out as follows:

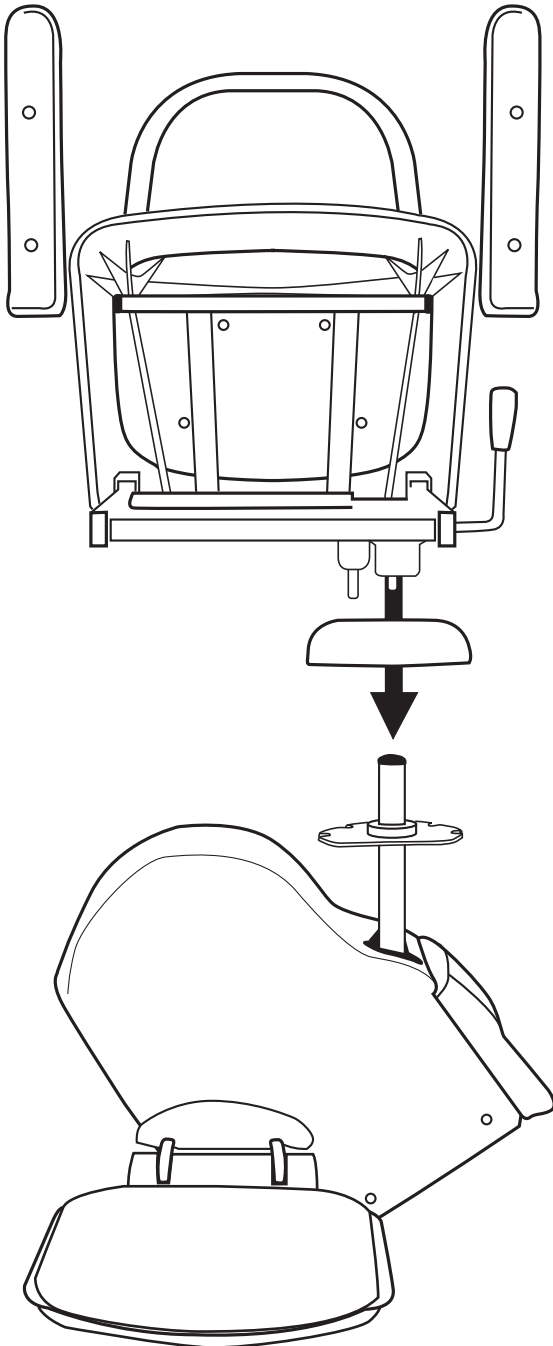

1. Fold up the seat arms and seat base.
2. Fit the Seat Index Plate Cover. Ensure that all wires are clear and will not become trapped.

Position the index plate as shown below.

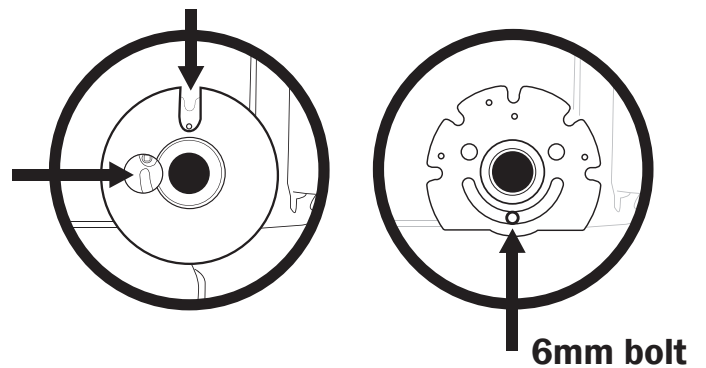

Ensure that the 6mm bolt is tightened.
This prevents the seat from turning more than 90°.

3. Position the seat on top of the seat post protruding from the chassis.
4. Fit seat post retaining plug.

5.

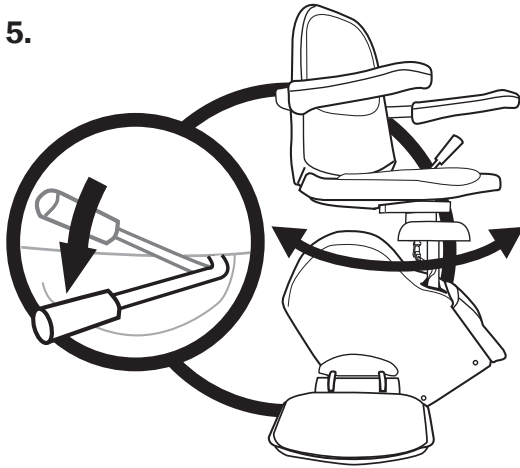

With the seat facing across the stairs, hold the swivel locking handle down, and gently twist the seat from side to side, easing it downwards.

Do this until the seat will not lower any more, and check that the seat post appears flush with the top of the seat frame.

6.

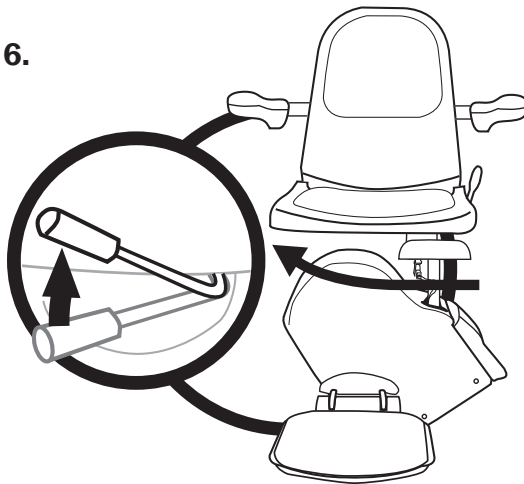

Release the seat swivel lever and rotate the seat until it is locked into the normal riding position – facing across the stairs.

7.

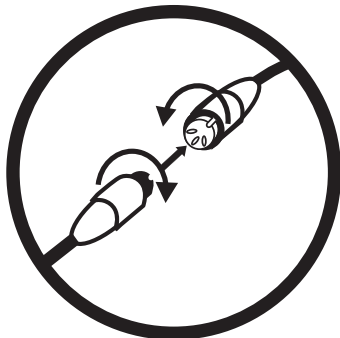

Connect the electrical connection between the seat and the carriage, by pushing together the 'DIN' plugs, and screwing the collars to ensure a safe, permanent connection.

8.

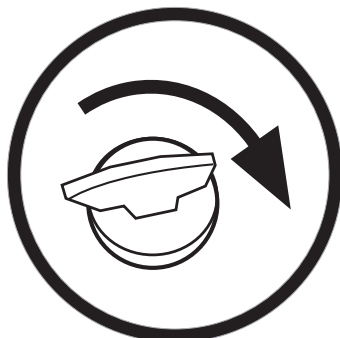

Check that the key switch on the carriage is in the 'ON' position and that the seat is in a locked position facing across the stairs (see point 5).

When all parts are correctly located, the LED display will show **F1** and beep showing the charging system is not connected to the mains. If other codes are displayed, refer to the error codes in the User Manual.

9.

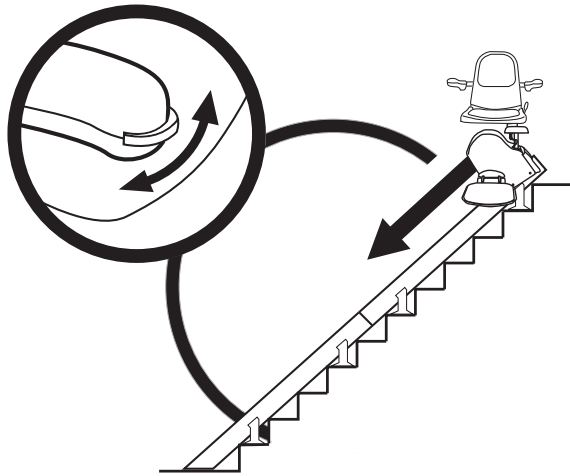

The stairlift can now be 'driven' downwards to locate the motor drive pinion on to the toothed rack on the rail. Operate the toggle switch on the chair arm towards downstairs (in the direction of travel).

The lift should cleanly locate on the rack and begin its first descent.

10.

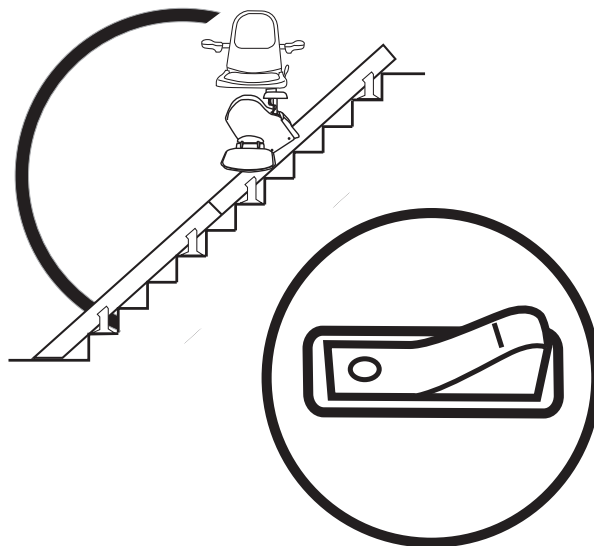

Stop the lift 3 or 4 steps down and switch off the battery isolation switch.

This is to stop the 'Batteries Off Charge' warning signal.

1.2.8 Setting Top Stopping Point

1.

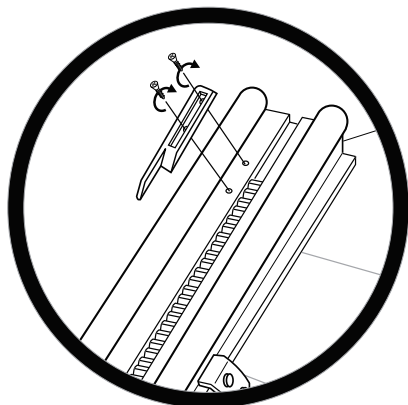

Replace the top stopping limit ramp; but do not fully tighten the screws at this point.

2.

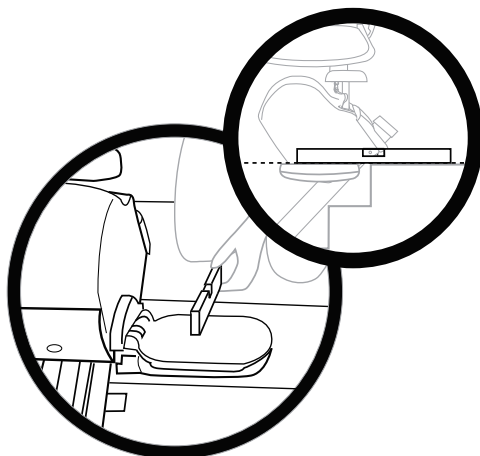

Switch the power back on to operate the stairlift.

Run the stairlift back to the top of the stairs until it comes to a full stop.

Check how level the footrest is with the landing using the spirit level.

3.

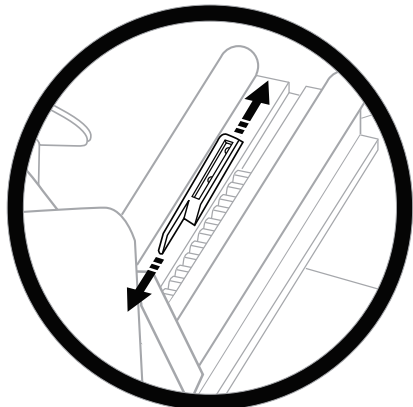

If the footrest IS NOT level with the landing, run the stairlift down 3 / 4 stairs and stop.

Slide the stopping ramp up or down to a suitable position.

Run the stairlift back to the top of the stairs and check to see if the footrest is level with the landing.

If not, repeat until correct.

When the top stopping position is correct tighten the screws on the stopping ramp.

4.

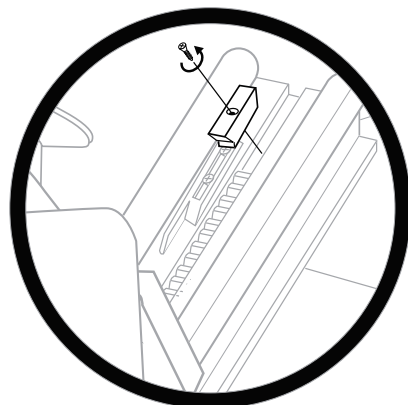

Position the plastic rail end stop at the end of the gear rack and drill a 3mm hole into the aluminium rail. Secure using the screw provided.



In cases where it is necessary to cut the rail and gear rack to length, this plastic end stop will secure and prevent any possible movement of loose gear rack.

1.2.9

Fixing Down the Rail

1. Run the stairlift down to the bottom of the staircase.
2. Visually check that the rail is parallel to the adjacent wall, and looking up the stairs, check behind the seat to ensure that the stairlift will not catch the wall on the way up.
3. Also check that there are no obstructions such as window sills.

There should be approximately 25mm between the seat back and the wall to avoid trapping hazards.

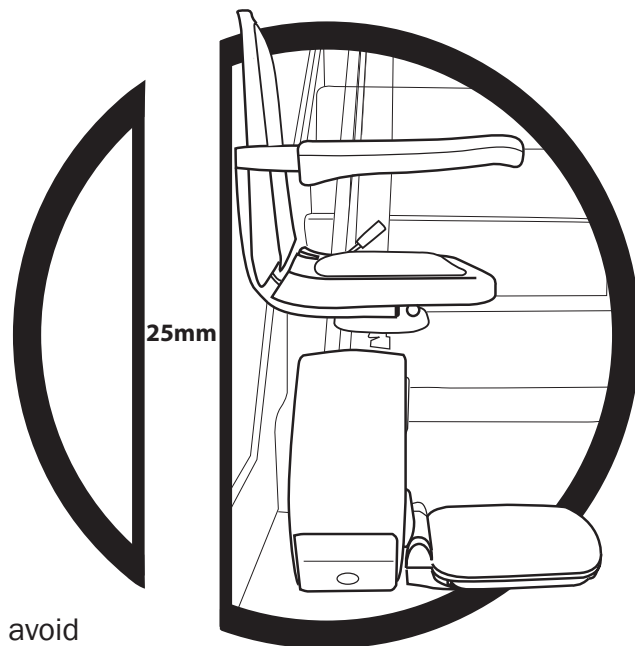

4. Adjust the clearance between the stairlift and the wall by moving the rail in or out appropriately.

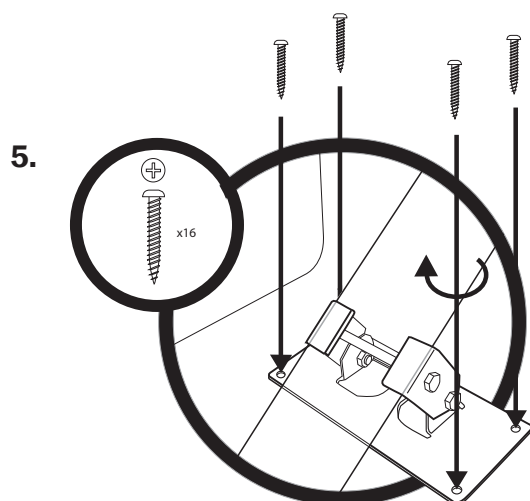

Once checked and final position verified, screw the rail brackets down to the stairs using the screws provided (four per bracket).

1.2.10

Connecting the Transformer



DO NOT plug the transformer into the mains socket YET!



The transformer from the fitting kit now needs to be connected to the charge system wiring as follows:

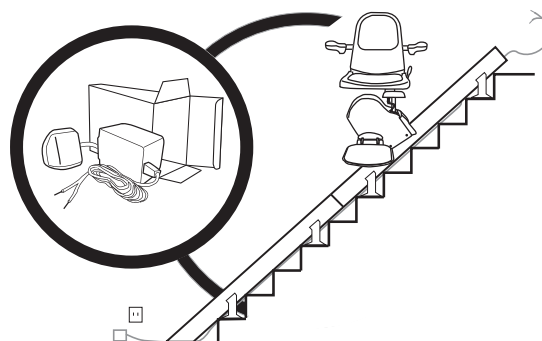

1. Insert the transformer lead through the hole on the underside of the rail (rubber-grommit) and out through the end of the rail.



2. Pull out the charge point wires and connector block from the end of the Rail and join the wires from the transformer to the connector block. The transformer output is AC, either wire can be connected to either terminal.

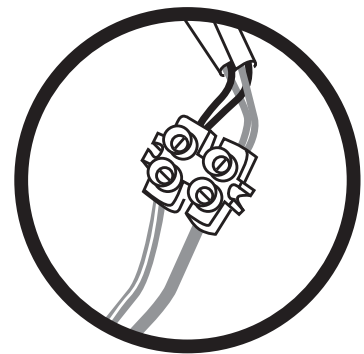

3. Push the jointed wires and connector block back into the rail end, push the rail end cap from the fitting kit over the end of the rail.

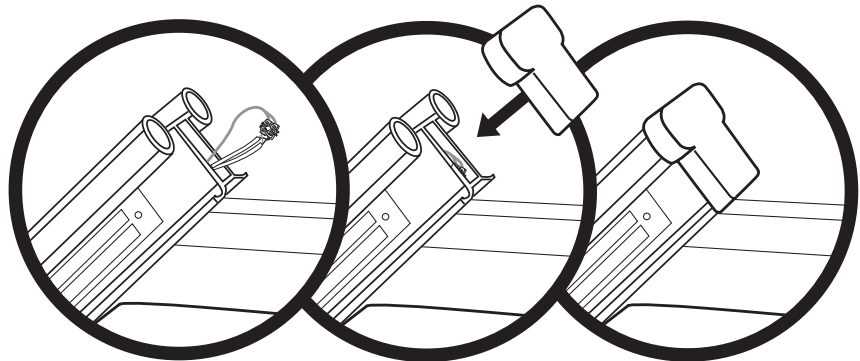

Ensure that the transformer wire is neatly routed so it will not cause a tripping hazard or get caught by the moving stairlift.



Plug in the transformer only on completion.

1.3 SAFETY CHECKS

Checklist - to be completed after installation and, if applicable, recorded on the installation work report by ticking the appropriate box and making supplementary notes as required.

1.3.1 Check Controls

1.

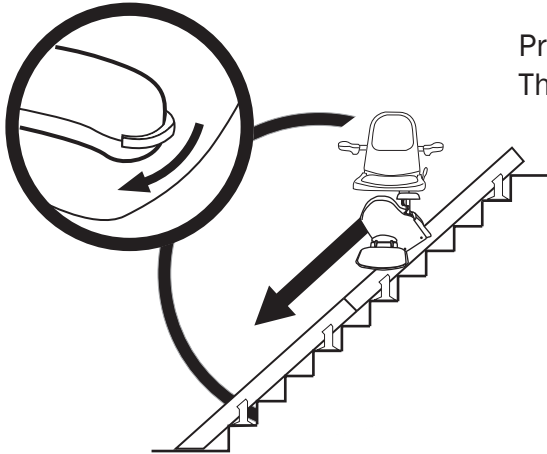

Press the toggle in the 'DOWN' direction.
The stairlift should start to travel down.

2.

Press the toggle switch in the 'UP' direction. The stairlift should start to travel upwards.

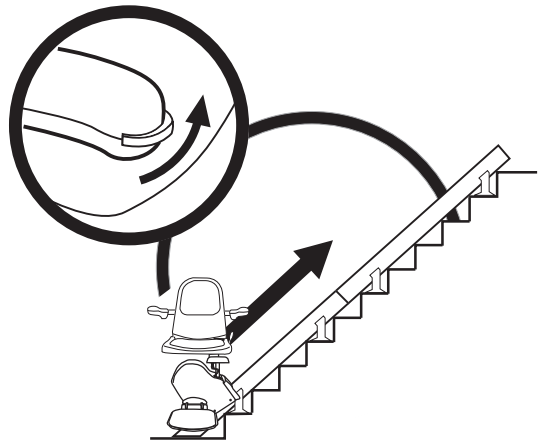

1.3.2 Check Remote Controls

1.

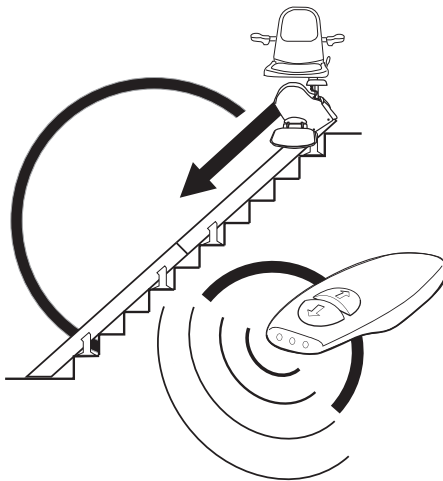

Press the GREEN or DOWN button on the remote and the stairlift will descend.

By releasing the button the stairlift will stop travelling.

2.

Press the RED or UP button on the remote and the stairlift will travel upwards.

By releasing the button the stairlift will stop travelling.

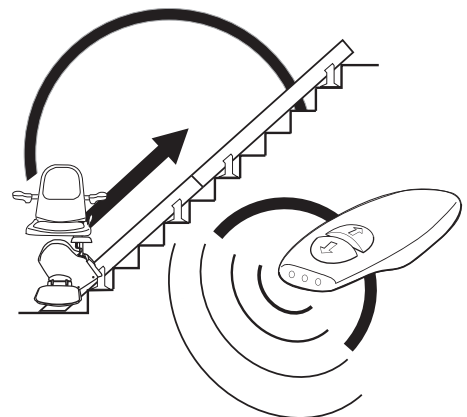

Remote Control handsets may vary.

1.3.3 Check Safety Sensors

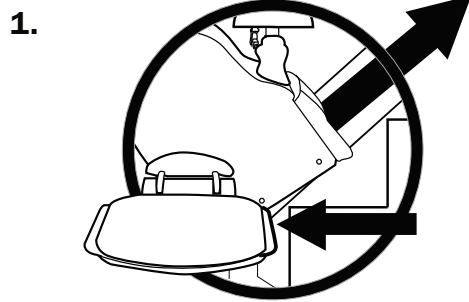

Footrest 'top' side sensor - with the lift ascending, push the top-side spring-loaded edge of footrest - the lift should stop immediately.

LED Display will show **E1**

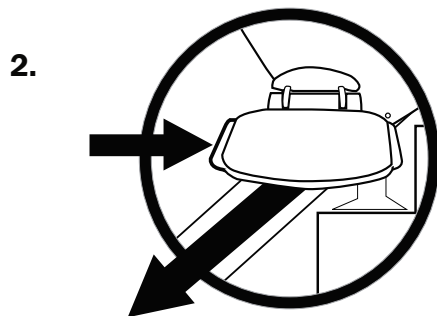

Footrest 'bottom' side sensor - with the lift descending, push the bottom-side spring-loaded edge of the footrest - the lift should stop immediately.

LED Display will show **E2**

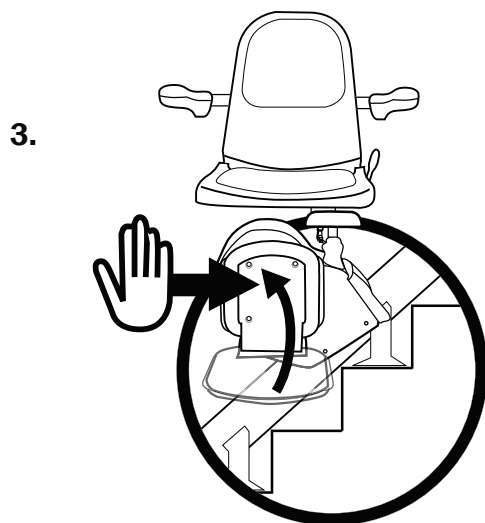

Footrest base sensor - with the lift descending, **push in the base of the footrest** - the lift should stop immediately.

LED Display will show **E2**

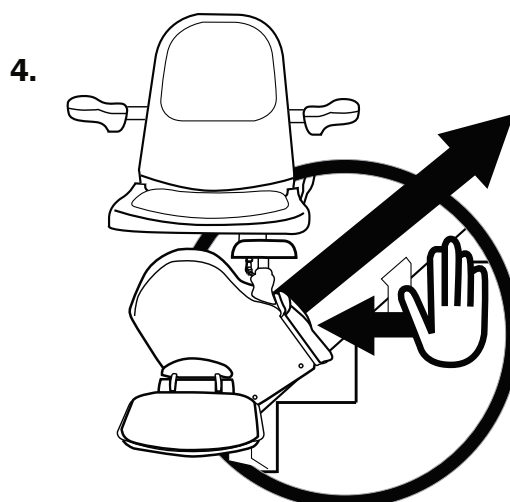

Carriage 'top' side sensor - with the lift ascending, push the top-side spring-loaded moulding attached to the carriage, immediately surrounding the rail - the lift should stop immediately.

LED Display will show **E3**

5.

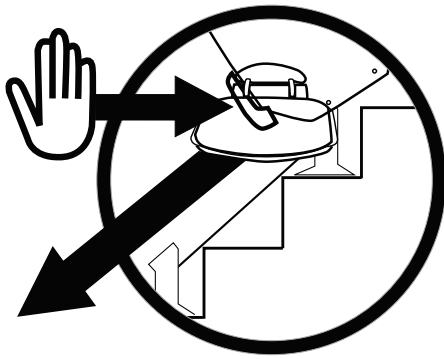

Carriage 'bottom' side sensor - with the lift descending, push the bottom-side spring-loaded moulding attached to the carriage immediately above the rail - the lift should stop immediately.

LED Display will show **E4**

1.3.4 Check Stopping Limits

1.

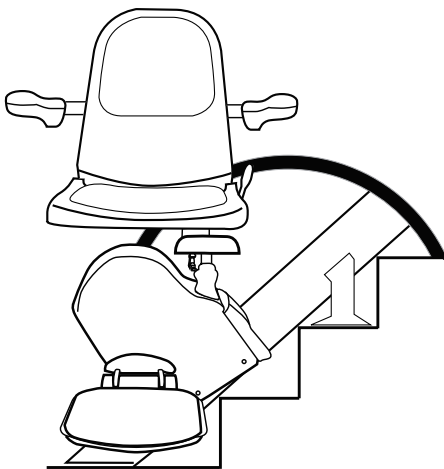

Bottom stopping limit operative - run the lift right to the bottom of the rail - the lift should automatically come to a 'soft' stop at the foot of the staircase.

2.

Top stopping limit operative - run the lift right to the top of the rail - the lift should automatically come to a 'soft' stop at the top of the staircase.

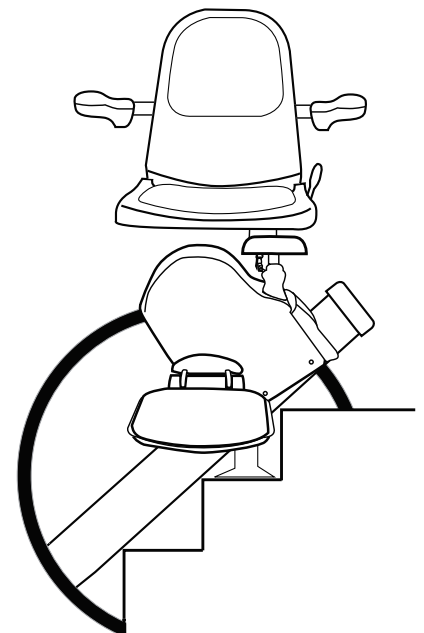

1.3.5 Check Seat Swivel

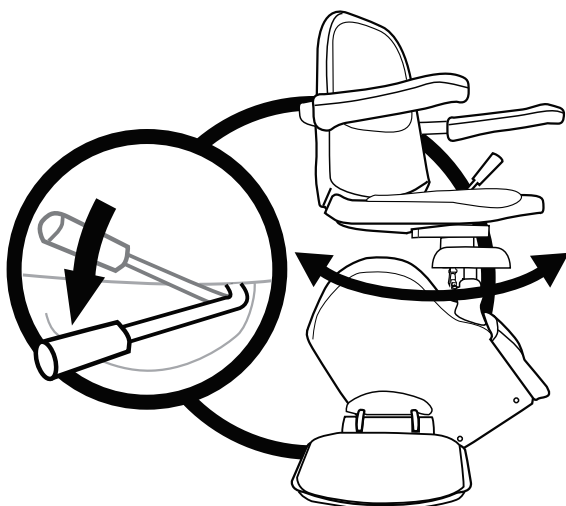

Turn the seat toward the top of the stairs away from the riding position.

The LED display should show **E5** and the stairlift will not operate

1.3.6 Check Battery Isolation Switch

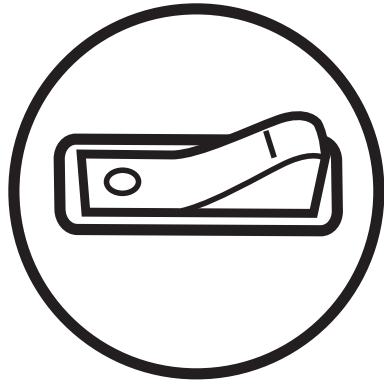

Turn the battery isolation switch to the OFF position or pull out the battery lead.

The LED display should go blank and the stairlift will not operate .

1.3.7 Check Key Switch

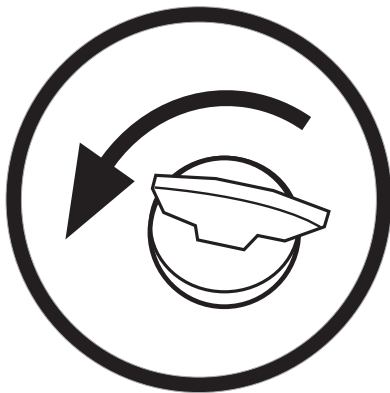

Turn the key switch to the off position. The LED display should change to and the stairlift will not operate .

1.3.8 Hand winding

Remove the blanking plug from the top of the carriage cover, insert the Hand Winding Wheel and turn a few turns observing the correct movement of the stairlift in both directions.

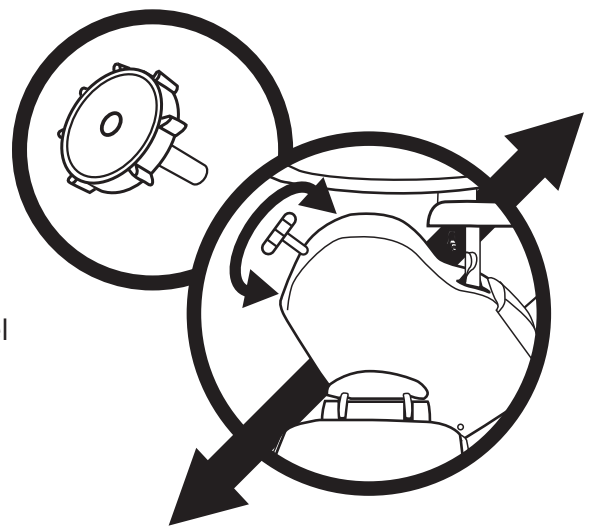

1.3.9 Labelling

Check all labels are affixed to the stairlift.

1.3.10 Check Correct Fixing of Carriage to Rail

Ride the stairlift up and down once, ensuring the ride is smooth and stable and that the stairlift stops in the correct positions at the top and bottom of the staircase.

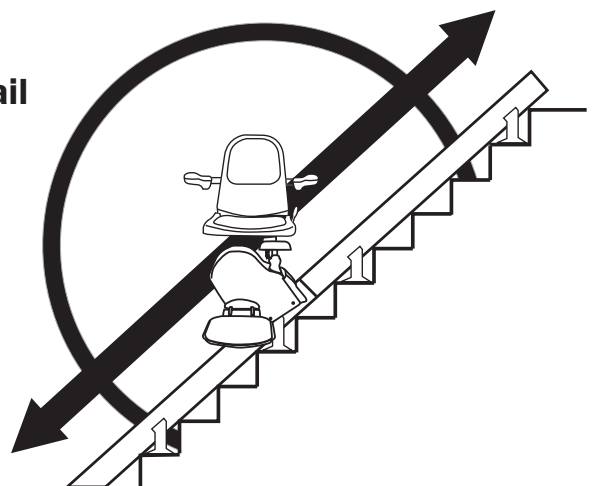

1.4 Demonstrate Stairlift to User (if applicable)

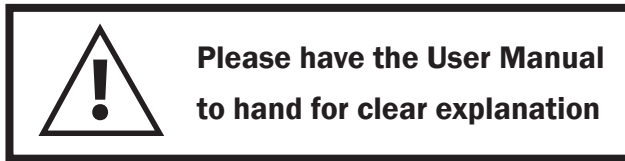

Correct operation of the stairlift, troubleshooting procedures and a description of the safety features must be demonstrated to the end user prior to hand over.

You should observe the user using the stairlift once upwards and once downwards **AT LEAST** until you are certain that they are able to use it safely.

If the user is unable to operate the stairlift correctly and safely, the stairlift should be removed, unless it is to be operated by an attendant. In this case, the attendant should be present at the installation.

1.5 Maintenance (if applicable)

Ensure that the purchaser is informed of requirements for the examination, testing and servicing of the stairlift and any associated national regulatory requirements.

1.6 Avoiding Unsafe Installations

- The installer should not proceed with installation if, for any reason, it is considered unsafe.
- If the user exceeds the safe working Load of 127Kg, (300lbs or 20 stones) the installation should not proceed.
- If any of the final safety checks fail, they should be repaired and re-tested before the stairlift is put into service. **Under no circumstances should any safety feature be overridden or disabled.**
- In the event that there is no wall or solid vertical surface behind the stairlift in its intended position, or on an open plan stairway the installation should not proceed until adequate shielding has been fitted.
- If the angle of the stairs is greater than 55° or less than 23° the installation should not proceed.

CONGRATULATIONS!

**You have installed
your Stairlift.**

**Don't forget to fill
in your registration
card!**

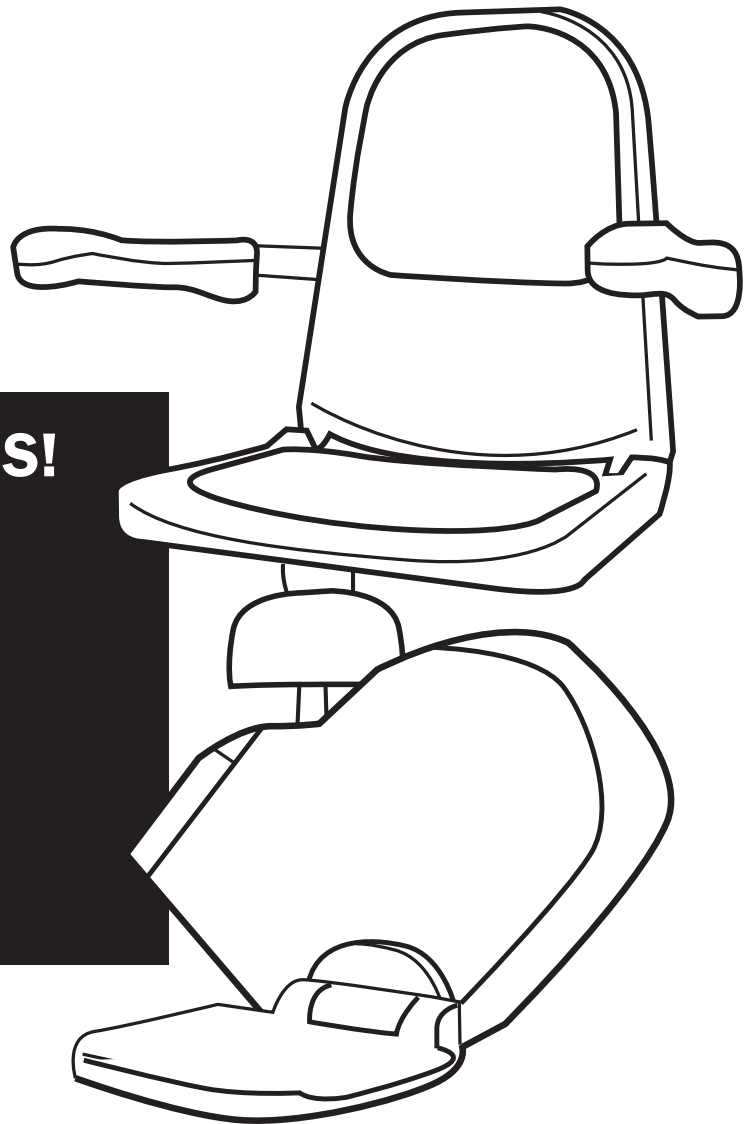

**In case of assistance, please
contact your Authorized Dealer**