

# CHICAGO

Electric<sup>®</sup>Power Tools

## ELECTRIC CHAINSAW SHARPENER

**Model 93213**

### SET UP AND OPERATING INSTRUCTIONS



Visit our website at: <http://www.harborfreight.com>



**Read this material before using this product.  
Failure to do so can result in serious injury.  
SAVE THIS MANUAL.**

Copyright<sup>®</sup> 2005 by Harbor Freight Tools<sup>®</sup>. All rights reserved. No portion of this manual or any artwork contained herein may be reproduced in any shape or form without the express written consent of Harbor Freight Tools. Diagrams within this manual may not be drawn proportionally. Due to continuing improvements, actual product may differ slightly from the product described herein. Tools required for assembly and service may not be included.

**For technical questions or replacement parts, please call 1-800-444-3353.**

Manual revised 10c

---

## SAVE THIS MANUAL

---

Keep this manual for the safety warnings and precautions, assembly, operating, inspection, maintenance and cleaning procedures. Write the product's serial number in the back of the manual near the assembly diagram (or month and year of purchase if product has no number). Keep this manual and the receipt in a safe and dry place for future reference.

---

## IMPORTANT SAFETY INFORMATION

---

In this manual, on the labeling, and all other information provided with this product:



This is the safety alert symbol. It is used to alert you to potential personal injury hazards. Obey all safety messages that follow this symbol to avoid possible injury or death.

### **DANGER**

**DANGER** indicates a hazardous situation which, if not avoided, will result in death or serious injury.

### **WARNING**

**WARNING** indicates a hazardous situation which, if not avoided, could result in death or serious injury.

### **CAUTION**

**CAUTION**, used with the safety alert symbol, indicates a hazardous situation which, if not avoided, could result in minor or moderate injury.

### **NOTICE**

**NOTICE** is used to address practices not related to personal injury.

### **CAUTION**

**CAUTION**, without the safety alert symbol, is used to address practices not related to personal injury.

---

## SAFETY WARNINGS AND PRECAUTIONS

---

**WARNING!** When using tool, basic safety precautions should always be followed to reduce the risk of personal injury and damage to equipment.

**Read all instructions before using this tool!**

1. **Keep guards in place** and in working order.
2. **Keep work area clean.** Cluttered areas invite injuries.
3. **Observe work area conditions.** Do not use machines or power tools in damp or wet locations. Don't expose to rain. Keep work area well lighted. Do not use electrically powered tools in the presence of flammable gases or liquids.
4. **Keep children away.** Children must never be allowed in the work area. Do not let them handle machines, tools, or extension cords.
5. **Make workshop kid proof** with padlocks, master switches, or by removing starter keys.
6. **Store idle equipment.** When not in use, tools must be stored in a dry location to inhibit rust. Always lock up tools and keep out of reach of children.
7. **Use the right tool for the job.** Do not attempt to force a small tool or

attachment to do the work of a larger industrial tool. There are certain applications for which this tool was designed. It will do the job better and more safely at the rate for which it was intended. Do not modify this tool and do not use this tool for a purpose for which it was not intended.

8. **Dress properly.** Do not wear loose clothing or jewelry as they can be caught in moving parts. Protective, electrically nonconductive clothes and nonskid footwear are recommended when working. Wear restrictive hair covering to contain long hair.
9. **Wear proper eye protection.** Always wear ANSI-approved impact safety goggles under a full face shield during use and service.
10. **Do not overreach.** Keep proper footing and balance at all times. Do not reach over or across running machines.
11. **Maintain tools with care.** Keep tools sharp and clean for better and safer performance. Follow instructions for lubricating and changing accessories. Inspect tool cords periodically and, if damaged, have them repaired by an authorized technician. The handles must be kept clean, dry, and free from oil and grease at all times.
12. **Avoid unintentional starting.** Be sure the switch is in the Off position when not in use and before plugging in.
13. **Stay alert.** Watch what you are doing, use common sense. Do not operate any tool when you are tired.
14. **Check for damaged parts.** Before using any tool, any part that appears damaged should be carefully checked to determine that it will operate properly and perform its intended function. Check
15. **Guard against electric shock.** Prevent body contact with grounded surfaces such as pipes, radiators, ranges, and refrigerator enclosures.
16. **Replacement parts and accessories.** When servicing, use only identical replacement parts. Use of any other parts will void the warranty. Only use accessories intended for use with this tool. Approved accessories are available from Harbor Freight Tools.
17. **Do not operate tool if under the influence of alcohol or drugs.** Read warning labels on prescriptions to determine if your judgment or reflexes are impaired while taking drugs. If there is any doubt, do not operate the tool.
18. **Maintenance.** For your safety, maintenance should be performed regularly by a qualified technician.
19. **Secure tool to worktable.**
20. **Turn off before moving chain.**
21. **Never use the Electric Chainsaw Sharpener around flammable materials.**
22. **This product contains lead, which is a chemical known to the State of California to cause cancer and birth defects or other reproductive harm.** (California Health & Safety Code § 25249.5, *et seq.*)
23. **Exposure to aluminum oxide (a dust generated from material removing**

REV 07h; 09h

SKU 93213

For technical questions, please call 1-800-444-3353.

Page 3

**processes) can result in eye, skin and breathing irritation.** Always use a NIOSH (National Institute for Occupational Safety and Health) approved respirator and safety goggles. Avoid skin exposure.

24. People with pacemakers should consult their physician(s) before use. Electromagnetic fields in close proximity to heart pacemaker could cause pacemaker interference or pacemaker failure.
25. **WARNING:** Handling the cord on this product will expose you to lead, a chemical known to the State of California to cause cancer, and birth defects or other reproductive harm. Wash hands after handling.  
(California Health & Safety Code § 25249.5, *et seq.*)
26. **The warnings, cautions, and instructions discussed in this instruction manual cannot cover all possible conditions and situations that may occur. It must be understood by the operator that common sense and caution are factors which cannot be built into this product, but must be supplied by the operator.**

### **Grinding Wheel Warnings**

1. Do not use a grinding wheel if it is chipped, cracked, or worn. You can check if the wheel has cracks not visible to the human eye by hanging it up by the central hole and tapping it with a nonmetallic object (ie: screwdriver handle). If it is in good condition it will produce a metallic sound. A dull sound indicates a crack or break.
2. Only use grinding wheels that fit the Arbor (7/8"). Do not try to change or modify the mounting hole on a grinding wheel to make it fit. Grinding wheel

replacements are available at Harbor Freight Tools.

3. Do not overtighten the Grinder Lock Cap (9). Hand tighten it only. Overtightening may cause the wheel to break or disintegrate.
4. Never use the Chainsaw Sharpener without the Grinding Wheel Cover (11B) in place.
5. Always test the Grinding Wheel (8) by running it for a minute prior to contact with a chain.
6. Keep away from the wheel when it is turning, and make sure no one is standing close, in the line of the wheel rotation trajectory.
7. If the grinding wheel vibrates, turn off the machine immediately and check that it is mounted securely, and that is not damaged.
8. Never try to stop the grinding wheel with your hands, even if you are wearing safety gloves. The wheel will cut through gloves and your hand, causing serious injury.
9. Never operate tool without the Grinding Wheel Cover in place.
10. Replacement grinding wheel listed speed must meet or exceed RPM rating of the tool.
11. Use only flanges furnished with the tool.
12. This machine is designed to sharpen chainsaw chains. Do not attempt to sharpen any other tools, and do not attempt to grind any other objects.

REV 09b

SKU 93213

**For technical questions, please call 1-800-444-3353.**

Page 4

---

## GROUNDING

---

### **⚠️ WARNING** TO PREVENT ELECTRIC SHOCK

#### AND DEATH FROM INCORRECT GROUNDING WIRE CONNECTION:



Check with a qualified electrician if you are in doubt as to whether the outlet is properly grounded. Do not modify the power cord plug provided with the tool. Never remove the grounding prong from the plug. Do not use the tool if the power cord or plug is damaged. If damaged, have it repaired by a service facility before use. If the plug will not fit the outlet, have a proper outlet installed by a qualified electrician.

---

### **Grounded Tools: Tools with Three Prong Plugs**

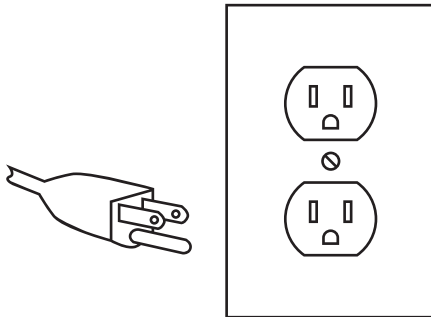

**3-Prong Plug and Outlet**

1. Tools marked with “Grounding Required” have a three wire cord and three prong grounding plug. The plug must be connected to a properly grounded outlet. If the tool should electrically malfunction or break down, grounding provides a low resistance path to carry electricity away from the user, reducing the risk of electric shock. **(See 3-Prong Plug and Outlet.)**

2. The grounding prong in the plug is connected through the green wire inside the cord to the grounding system in the tool. The green wire in the cord must be the only wire connected to the tool’s grounding system and must never be attached to an electrically “live” terminal. **(See 3-Prong Plug and Outlet.)**
3. The tool must be plugged into an appropriate outlet, properly installed and grounded in accordance with all codes and ordinances. The plug and outlet should look like those in the preceding illustration. **(See 3-Prong Plug and Outlet.)**

---

### **Double Insulated Tools: Tools with Two Prong Plugs**

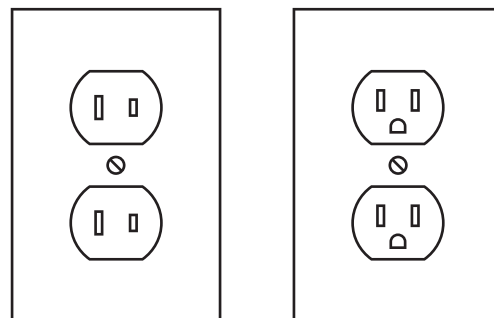

**Outlets for 2-Prong Plug**

1. Tools marked “Double Insulated” do not require grounding. They have a special double insulation system which satisfies OSHA requirements and complies with the applicable standards of Underwriters Laboratories, Inc., the Canadian Standard Association, and the National Electrical Code. **(See Outlets for 2-Prong Plug.)**
2. Double insulated tools may be used in either of the 120 volt outlets shown in the preceding illustration. **(See Outlets for 2-Prong Plug.)**





## Extension Cords

1. **Grounded** tools require a three wire extension cord. **Double Insulated** tools can use either a two or three wire extension cord.
2. As the distance from the supply outlet increases, you must use a heavier gauge extension cord. Using extension cords with inadequately sized wire causes a serious drop in voltage, resulting in loss of power and possible tool damage. **(See Table A.)**
3. The smaller the gauge number of the wire, the greater the capacity of the cord. For example, a 14 gauge cord can carry a higher current than a 16 gauge cord. **(See Table A.)**
4. When using more than one extension cord to make up the total length, make sure each cord contains at least the minimum wire size required. **(See Table A.)**
5. If you are using one extension cord for more than one tool, add the nameplate amperes and use the sum to determine the required minimum cord size. **(See Table A.)**
6. If you are using an extension cord outdoors, make sure it is marked with the suffix "W-A" ("W" in Canada) to indicate it is acceptable for outdoor use.
7. Make sure the extension cord is properly wired and in good electrical condition. Always replace a damaged extension cord or have it repaired by a qualified electrician before using it.
8. Protect the extension cords from sharp objects, excessive heat, and damp or wet areas.

<b>RECOMMENDED MINIMUM WIRE GAUGE FOR EXTENSION CORDS* (120/240 VOLT)</b>					
<b>NAMEPLATE AMPERES (at full load)</b>	<b>EXTENSION CORD LENGTH</b>				
	<b>25'</b>	<b>50'</b>	<b>75'</b>	<b>100'</b>	<b>150'</b>
0 – 2.0	18	18	18	18	16
2.1 – 3.4	18	18	18	16	14
3.5 – 5.0	18	18	16	14	12
5.1 – 7.0	18	16	14	12	12
7.1 – 12.0	18	14	12	10	-
12.1 – 16.0	14	12	10	-	-
16.1 – 20.0	12	10	-	-	-

**TABLE A**      \* Based on limiting the line voltage drop to five volts at 150% of the rated amperes.

## Symbology

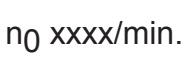
	Double Insulated
	Canadian Standards Association
	Underwriters Laboratories, Inc.
	Volts Alternating Current
	Amperes
	No Load Revolutions per Minute (RPM)

---

## SPECIFICATIONS

---

Motor	120 V~, 0.75 A (Load), Direct Drive
RPM	4200
Vise Capacity	0.80" to 0.50"
Table / Vise Angles	35° Right to Left
Arbor Diameter	7/8"
Wheel Dimensions	4-1/4" Dia. x 1/8" Thick
Working time	S3:10S ON / 15S OFF

**Note:** Performance of this tool (if powered by line voltage) may vary depending on variations in local line voltage. Extension cord usage may also affect tool performance.

---

## UNPACKING

---

When unpacking, make sure that the item is intact and undamaged. If any parts are missing or broken, please call Harbor Freight Tools at 1-800-444-3353 as soon as possible.

---

## ASSEMBLY

---

**WARNING!** Unplug the tool before changing grinding wheels, or before making any adjustments to the tool.

### Installation

1. Install the Sharpener to a workbench before use.

**FIGURE 1**

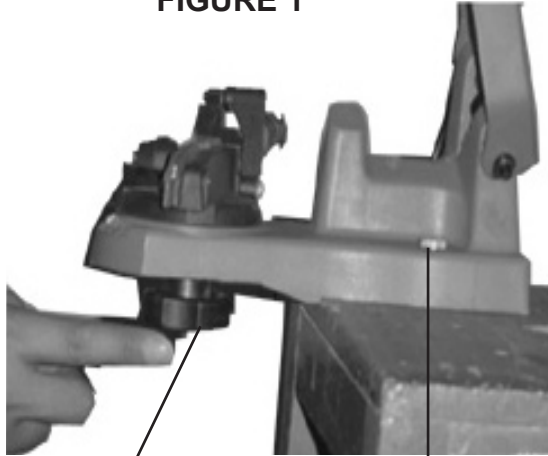

**Lock Wheel (18)**

**1/4" Hole  
with Bolt**

1. When installing the sharpener on a workbench, make sure that the **Lock Wheel (18)** is accessible, as shown in the mounting picture in **FIGURE 1**.

**FIGURE 2**

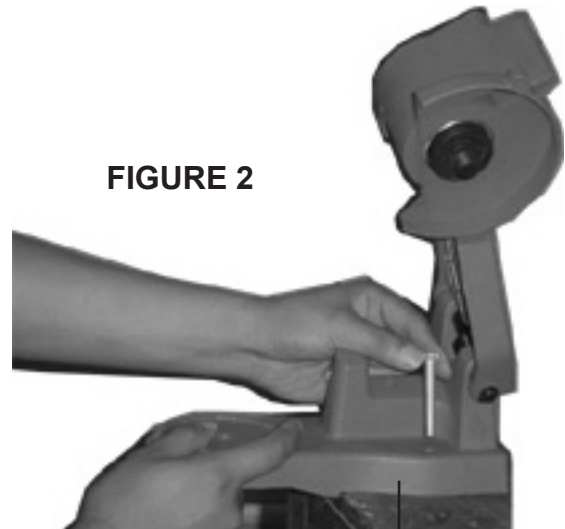

**Base (17)**

2. Bolt (bolts not included) the unit directly to the workbench through the two 1/4" holes on the **Base (17)**. The workbench must have a solid surface capable of supporting the weight of this product, the workpiece and assorted tools. See **FIGURE 2**.



## Mounting a Grinding Wheel

Refer to the Assembly Drawing on page 10.

**FIGURE 3**

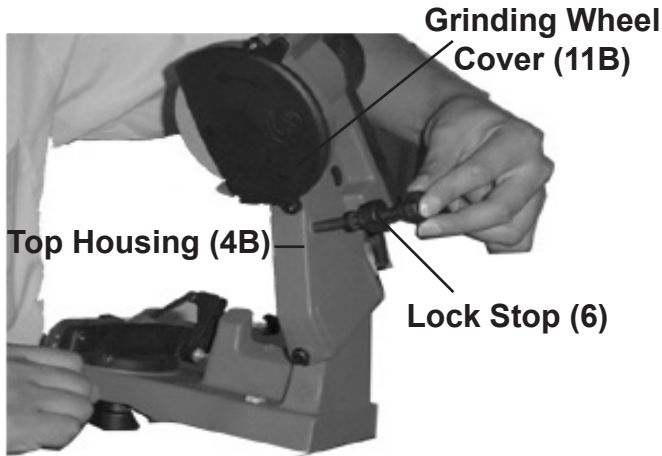

1. Raise the Top Housing (4B) and lock it in the up position by tightening the Lock Stop (6).
2. Remove the four screws holding the Grinding Wheel Cover (11B). Set the cover aside.

**FIGURE 4**

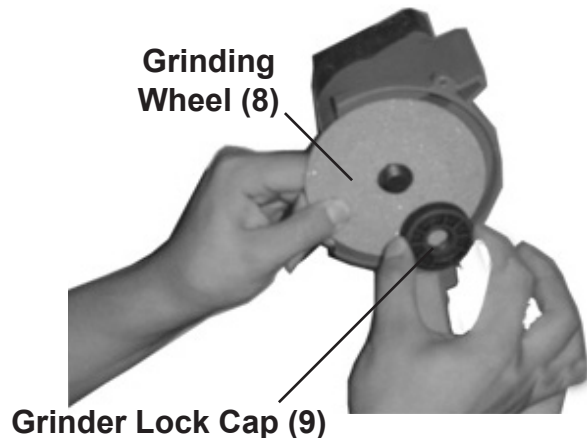

3. Unscrew the Grinder Lock Cap (9) that holds the Grinding Wheel (8) in place.
4. Install the new wheel on the Grinding Wheel Base (7), making sure it fits properly.

**Note:** Do not use a grinding wheel if it is chipped, cracked, or worn. You can check if the wheel has cracks not visible

to the human eye by hanging it up by the central hole and tapping it with a non metal object (ie: screwdriver handle). If it is in good condition it will produce a metallic sound. A dull sound indicates a crack or break.

5. Replace the Grinder Lock Cap (9).
6. Replace the Grinding Wheel Cover (11B).
7. Release the Lock Stop (6) and lower the Top Housing (4B).
8. Never operate tool without the Grinding Wheel Cover in place.

---

## OPERATION

---

**WARNING!** Unplug the unit before adjusting chain to be sharpened.

Refer to the Assembly Drawing on page 10 and the various photographs.

**Note:** Raise the Top Housing (4B) while adjusting the chain.

1. Clean the chain before sharpening. Wash it with a nonflammable solvent. Do not use gasoline. Dry the chain.

**FIGURE 6**

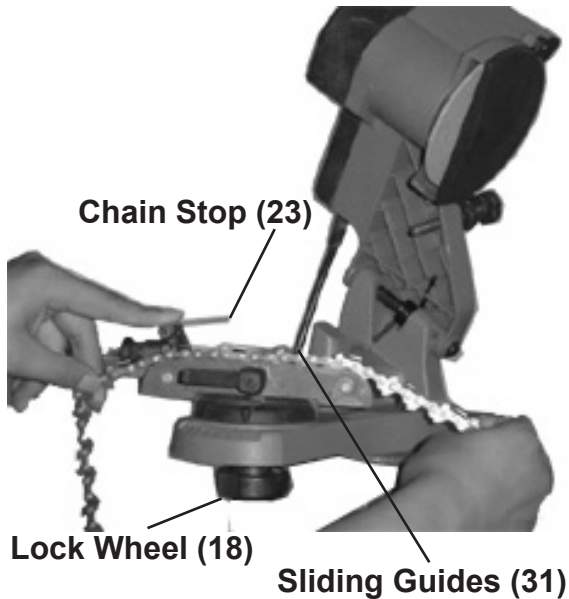

2. Lift up the Chain Stop (23) and secure the chain in the Sliding Guides (31). See **FIGURE 6**.

**FIGURE 5**

Tip of Chain Stop positioned against tooth.

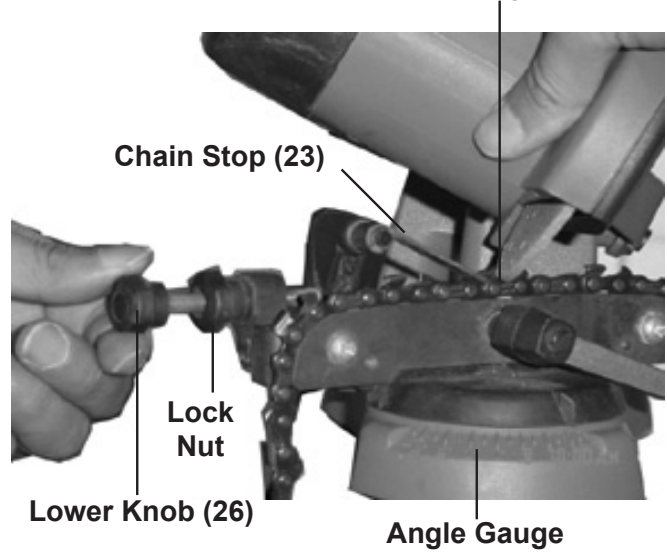

3. Lower the Chain Stop (23) so that it is positioned on the tooth (cutter) you want to start with. See **FIGURE 5**.
4. See **FIGURES 5 & 6**. Loosen the Lock Wheel (18) to allow entire housing to turn. Rotate the housing to match the degree of angle you need on the Angle Gauge. Chains come in various sizes with varying degrees of sharpening angles. Check with your chain manufacturer's manual to determine what degree you need to sharpen at. Once the degree is set, tighten the Lock Wheel (18).
5. Lower the Top Housing (4B) so that the Grinding Wheel (8) skims the chain tooth.

**FIGURE 7**

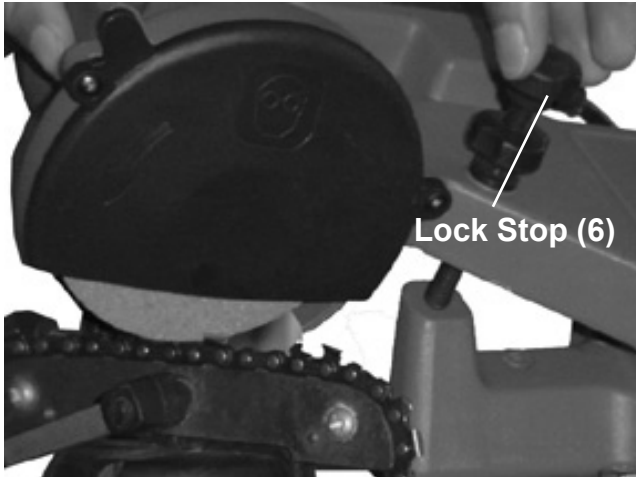

6. Hold it at that position while you tighten the **Lock Stop (6)** so that the wheel will only go down to that point. See **FIGURE 7**.
7. Depending on the amount of material you wish to remove, tighten or loosen the Lower Knob (26) and set the Lock Nut. See **FIGURE 5**. The Lower Knob (26) has a Lock Nut which will determine how much material is removed. Once you set the Lock Nut, fully tighten the Lower Knob (26).

**FIGURE 8**

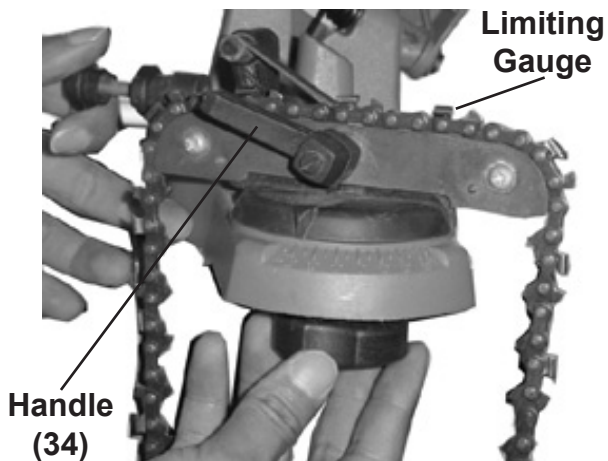

8. Lock the chain in the Sliding Guides (31) by turning the Handle (34). See **FIGURE 8**. The Handle (34) should be situated so that you can easily release and tighten it. You will need to release it each time you

move to the next link, and tighten it to sharpen each link.

**FIGURE 9**



9. If the chain has been repeatedly sharpened, the chain depth limiting gauges may need to be taken down with a flat file (not included). See **FIGURES 8 & 9**. File down each gauge so that they are at a lower level than the cutting teeth.

### Sharpening

1. Put on your protective gear and make sure the immediate area is clear of bystanders.
2. Plug in the Power Cord (3) and push the Switch (5B) to turn on the machine.

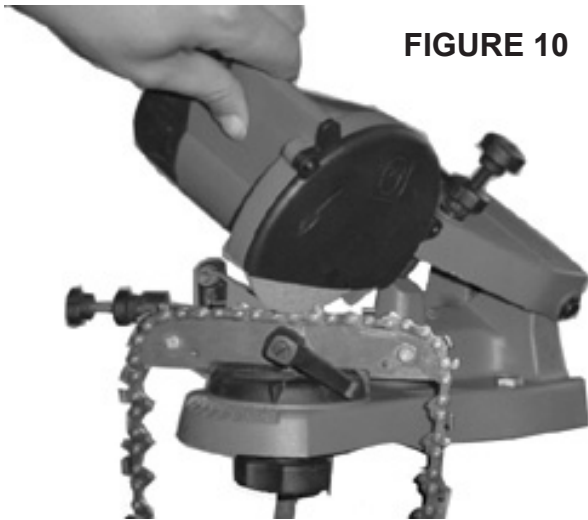
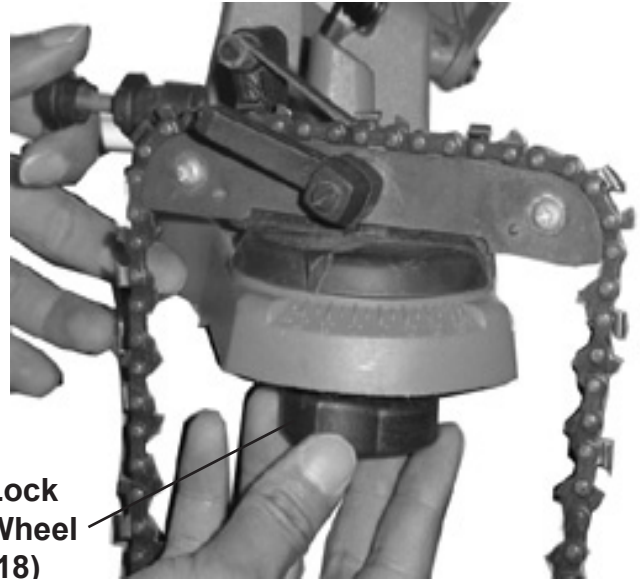

**FIGURE 10**

3. Slowly lower the grinding wheel as shown in **FIGURE 10**. If you notice slight errors in your settings, turn off the unit and unplug it before you make your adjustments.

**Note:** A good grind occurs when the contact between the wheel and the teeth are gradual and smooth. Do not stop too long on any tooth.

4. After sharpening one tooth, turn off the machine. Lift the Top Housing (4B), release the Handle (34), and move the chain so that the next link is positioned in the Chain Stop (23). Tighten the Handle (34). **Turn the machine back on and continue** sharpening the next tooth. Repeat this process until you have sharpened all of the links set up for this angle.



**FIGURE 11**

**Lock Wheel (18)**

5. After you finished sharpening all of the teeth set for your current angle, turn off the machine by pushing the Switch (5B) and unplugging the unit. **See FIGURE 11**
6. Loosen the Lock Wheel (18) and reset the angle so that the first tooth that hasn't been sharpened is positioned against the Chain Stop (23) and locked in, as explained on page 6.
7. As you did with the first half of the chain, be sure to lower the Top Housing (4B) so that the Grinding Wheel (8) skims the chain tooth, and lock it in place. See page 6. Follow all of the steps on page 6 double checking everything before you plug in the machine and turn it on again.

**WARNING!** Remember to turn off the machine and unplug it if you need to make any adjustments.

8. After you repeat all of the steps under Sharpening on page 7, your chain is ready to be mounted on your saw.

---

## **MAINTENANCE**

---

1. Keep the Sharpener clean and free of dust, metal debris and dirt.
2. Check the Grinding Wheel before each use to make sure it isn't damaged. Do not use a grinding wheel if it is chipped, cracked, or worn. You can check if the wheel has cracks not visible to the human eye by hanging it up by the central hole and tapping it with a non metal object (ie: screwdriver handle). If it is in good condition it will produce a metallic sound. A dull sound indicates a crack or break.
3. Replace the Grinding Wheel when it grinds down to a diameter of 3 inches.

## PARTS LIST

Part	Description	Q'ty
1	Screw	3
2	Motor Cover	1
3	Power Cord	1
4B	Top Housing	1
5B	Rocker Switch	1
6	Lock Stop	1
7	Grinding Wheel Base	1
8	Grinding Wheel	1
9	Grinder Lock Cap	1
10	Screw	2
11B	Grinding Wheel Cover	1
12	O-ring	2
13	Punching Axis	1
14	Torsion Spring	1
15B	Switch Circuit Board	1
16	Nut	1
17	Base	1
18	Lock Wheel	1
19*	Screw	1

Part	Description	Q'ty
20*	Washer	1
21*	Bearing	1
22*	Swing Arm	1
23*	Chain Stop	1
24*	Tension Spring	1
25*	Retaining Ring (5)	1
26*	Lower Knob	1
27*	Screw	1
28*	Bolt	1
29*	Chain Saw Frame	1
30*	Square Neck Screw	1
31*	Sliding Guide	2
32*	Pad	2
33*	Screw	2
34*	Handle	1
35*	Spring	1
36*	Lock Screw	1
37	Retaining Ring (10)	2
38	Motor	1

**\*Note:** The Chain Mounting Assembly (39) is only available as a set. It includes all part numbers with asterisks (\*). Part numbers with asterisks (19 through 36) are not available individually.

### PLEASE READ THE FOLLOWING CAREFULLY

THE MANUFACTURER AND/OR DISTRIBUTOR HAS PROVIDED THE PARTS DIAGRAM IN THIS MANUAL AS A REFERENCE TOOL ONLY. NEITHER THE MANUFACTURER NOR DISTRIBUTOR MAKES ANY REPRESENTATION OR WARRANTY OF ANY KIND TO THE BUYER THAT HE OR SHE IS QUALIFIED TO MAKE ANY REPAIRS TO THE PRODUCT OR THAT HE OR SHE IS QUALIFIED TO REPLACE ANY PARTS OF THE PRODUCT. IN FACT, THE MANUFACTURER AND/OR DISTRIBUTOR EXPRESSLY STATES THAT ALL REPAIRS AND PARTS REPLACEMENTS SHOULD BE UNDERTAKEN BY CERTIFIED AND LICENSED TECHNICIANS AND NOT BY THE BUYER. THE BUYER ASSUMES ALL RISK AND LIABILITY ARISING OUT OF HIS OR HER REPAIRS TO THE ORIGINAL PRODUCT OR REPLACEMENT PARTS THERETO, OR ARISING OUT OF HIS OR HER INSTALLATION OF REPLACEMENT PARTS THERETO.

**Note:** Some parts are listed and shown for illustration purposes only and are not available individually as replacement parts.

# ASSEMBLY DRAWING

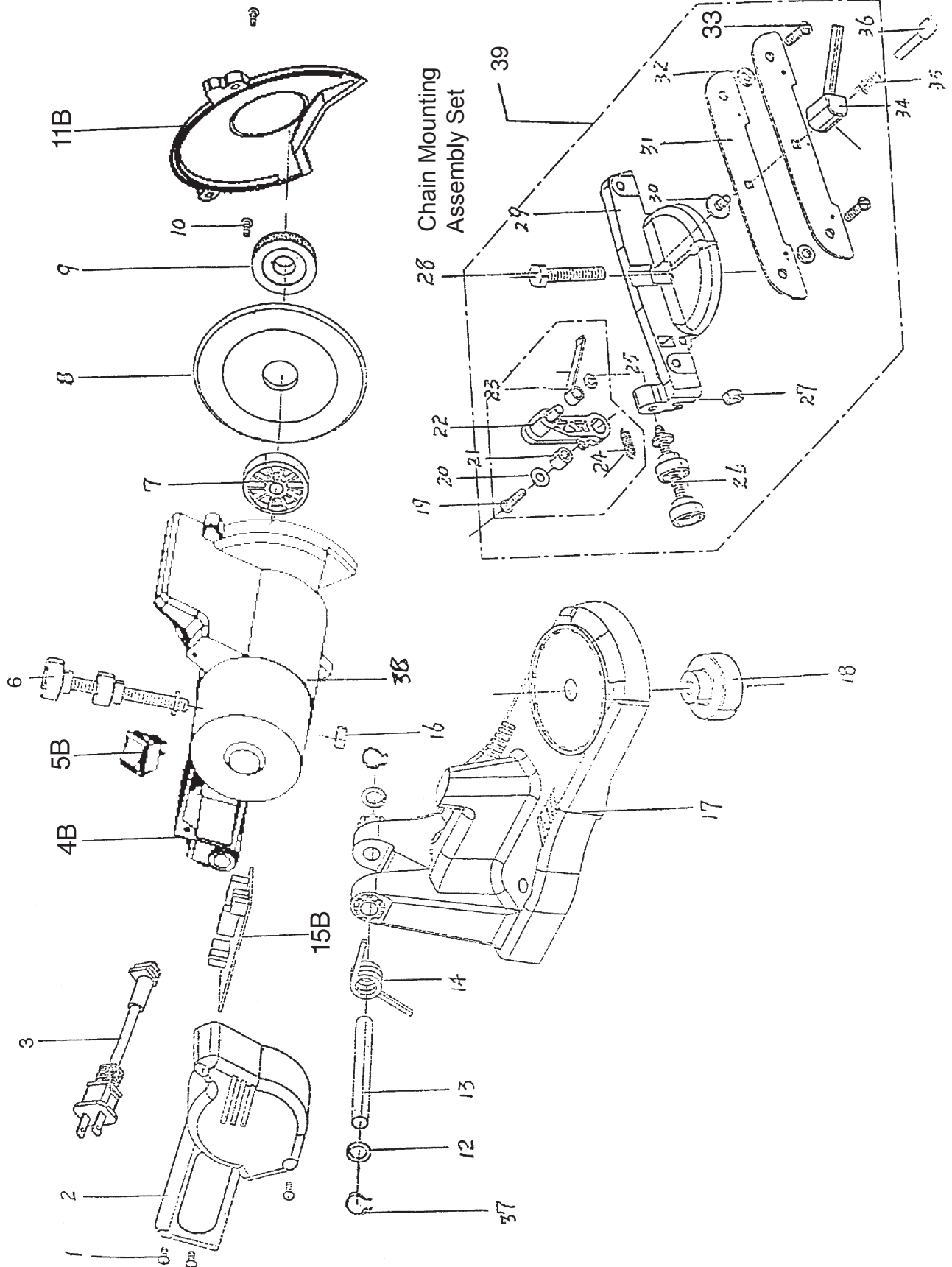

---

## LIMITED 90 DAY WARRANTY

---

Harbor Freight Tools Co. makes every effort to assure that its products meet high quality and durability standards, and warrants to the original purchaser that this product is free from defects in materials and workmanship for the period of 90 days from the date of purchase. This warranty does not apply to damage due directly or indirectly, to misuse, abuse, negligence or accidents, repairs or alterations outside our facilities, criminal activity, improper installation, normal wear and tear, or to lack of maintenance. We shall in no event be liable for death, injuries to persons or property, or for incidental, contingent, special or consequential damages arising from the use of our product. Some states do not allow the exclusion or limitation of incidental or consequential damages, so the above limitation of exclusion may not apply to you. THIS WARRANTY IS EXPRESSLY IN LIEU OF ALL OTHER WARRANTIES, EXPRESS OR IMPLIED, INCLUDING THE WARRANTIES OF MERCHANTABILITY AND FITNESS.

To take advantage of this warranty, the product or part must be returned to us with transportation charges prepaid. Proof of purchase date and an explanation of the complaint must accompany the merchandise. If our inspection verifies the defect, we will either repair or replace the product at our election or we may elect to refund the purchase price if we cannot readily and quickly provide you with a replacement. We will return repaired products at our expense, but if we determine there is no defect, or that the defect resulted from causes not within the scope of our warranty, then you must bear the cost of returning the product.

This warranty gives you specific legal rights and you may also have other rights which vary from state to state.

**3491 Mission Oaks Blvd. • PO Box 6009 • Camarillo, CA 93011 • (800) 444-3353**